

Radio control model

R/C Flugmodell

**INSTRUCTION MANUAL  
MONTAGEANLEITUNG**

# J3 - CUB

## U.S.ARMY

Designed for brushless electric motors (.46-.52 class glow conversion optional)

Entwickelt für Brushless Elektro Motoren (7,5 -8,5cc Glühzündermotor Einbau möglich)



### SPECIFICATIONS

Wingspan	63.7in.
Length	49.2 in.
Electric Motor	(See next page)
Glow Engine	.46 2Stroke / .52 4-Stroke
Radio	5 Channel / 4 -5 Servos

### TECHNISCHE DATEN

Spannweite	1620mm
Länge	1250mm
Elektroantrieb	(siehe nächste Seite)
Verbrennerantrieb	7.5cc 2-T / 8.5cc 4-T
Fernsteuerung	5 Kanal / 4 -5 Servos



**WARNING!** This radio controlled model is NOT a toy. If modified or flown carelessly it could go out of control and cause serious human injury or property damage. Before flying your airplane, ensure the air field is spacious enough. Always fly it outdoors in safe areas and seek professional advice if you are unexperienced.

**ACHTUNG!** Dieses ferngesteuerte Modell ist KEIN Spielzeug! Es ist für fortgeschrittene Modellflugpiloten bestimmt, die ausreichende Erfahrung im Umgang mit derartigen Modellen besitzen. Bei unsachgemäßer Verwendung kann hoher Personen- und/oder Sachschaden entstehen. Fragen Sie in einem Modellbauverein in Ihrer Nähe um professionelle Unterstützung, wenn Sie Hilfe im Bau und Betrieb benötigen. Der Zusammenbau dieses Modells ist durch die vielen Abbildungen selbsterklärend und ist für fortgeschrittene, erfahrene Modellbauer bestimmt.

## REQUIRED FOR OPERATION (Purchase separately)

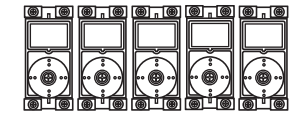
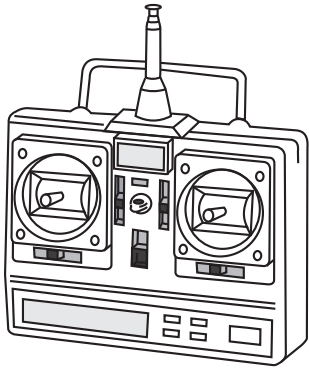

Minimum 5 channel radio for airplane with 5 servos



10.5x6 for .40 - 2 cycle engine  
 11x6 for .46 - 2 cycle engine  
 12x6 for .60 - 4 cycle engine  
 12x7 for .70 - 4 cycle engine  
 13x8 for G-46 HP Motor.

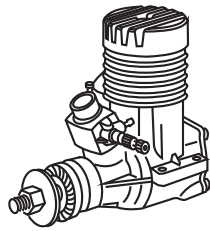

.46 ~ .50 - 2 cycle

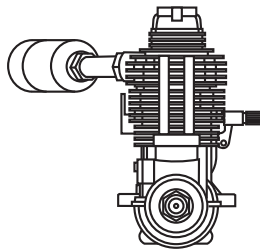

.60 ~ .70 - 4 cycle

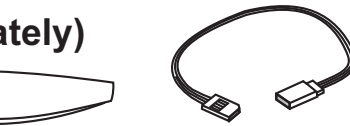

Extension for aileron servo, retract servo.

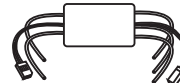

Motor Control

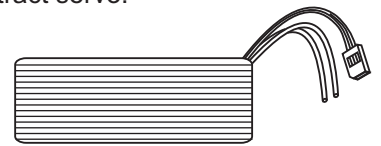

Li-Po Battery, 5 cell 4500mAh.

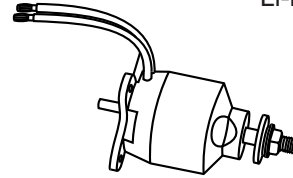

G-46 HP Motor or equivalent.



Silicone tube



Cyanoacrylate Glue  
Sekundenkleber



Silicon Glue  
Silikonkleber



Epoxy Glue (30 minutes type)  
Epoxy-Klebstoff (30min)

### Tool Required/ Empfohlenes Werkzeug

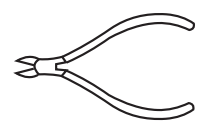
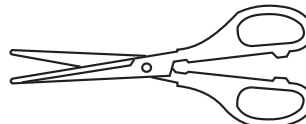
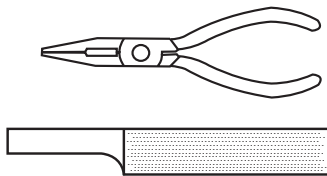



The pre-covered film on ARF kit may wrinkle due to variations of temperature. Store model in a cool and dry place for awhile. Then, starting with low heat, you may carefully use a hair dryer to smooth out wrinkles.

Die Bespannung des Modells kann durch Temperatureinflüsse erschlaffen oder Falten werfen z.b bei zu starker Sonneneinstrahlung oder Hitze. Stellen Sie das Modell zunächst an einen kühlen Platz für eine bestimmte Zeit. Danach können Sie versuchen die restlichen Falten vorstichtig mit einem Haartrockner zu behandeln.





 Drill holes using the stated size of drill (in this case 1.5 mm Ø)

 Take particular care here

 Hatched-in areas: remove covering film carefully

 Check during assembly that these parts move freely, without binding

 Use epoxy glue

 Apply cyano glue

 Assemble left and right sides the same way.

 Not included. These parts must be purchased separately

 Löcher bohren mit dem angegebenen Bohrer (hier 1,5 mm)

 Hier besonders aufpassen

 Schraffierte Stellen, Bespannfolie vorsichtig entfernen

 Während des Zusammenbaus immer prüfen, ob sich die Teile auch reibungslos bewegen lassen

 Epoxy-Klebstoff verwenden

 Sekundenkleber auftragen

 Linke und rechte Seite wird gleichermaßen zusammgebaut

 Nicht enthalten. Teile müssen separat gekauft werden.

### CONVERSION TABLE

1.0mm = 3/64"	3.0mm = 1/8"	10mm = 13/32"	25mm = 1"
1.5mm = 1/16"	4.0mm = 5/32"	12mm = 15/32"	30mm = 1-3/16"
2.0mm = 5/64"	5.0mm = 13/64"	15mm = 19/32"	45mm = 1-51/64"
2.5mm = 3/32"	6.0mm = 15/64"	20mm = 51/64"	

# 1

**A** Securely attach the engine mount to the fire-wall using the four 4x25mm screws.

*Note the side thrust for motor!*  
**Sturz und Zug beachten!**

Align the mark on both mounts with the center mark on the fire-wall

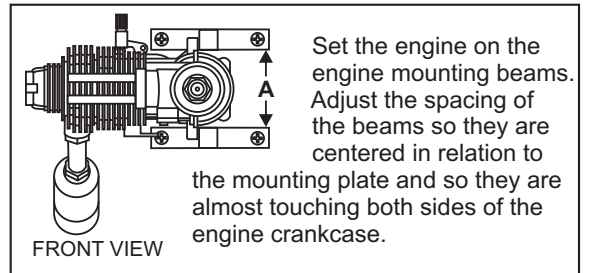
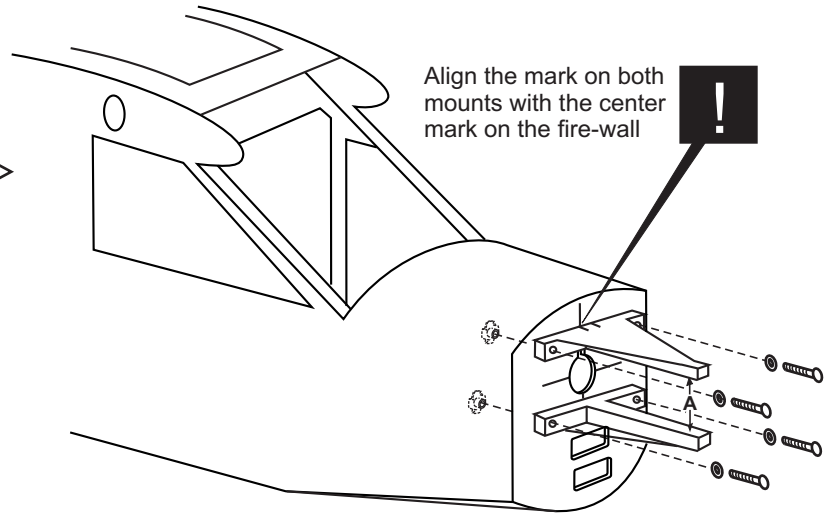
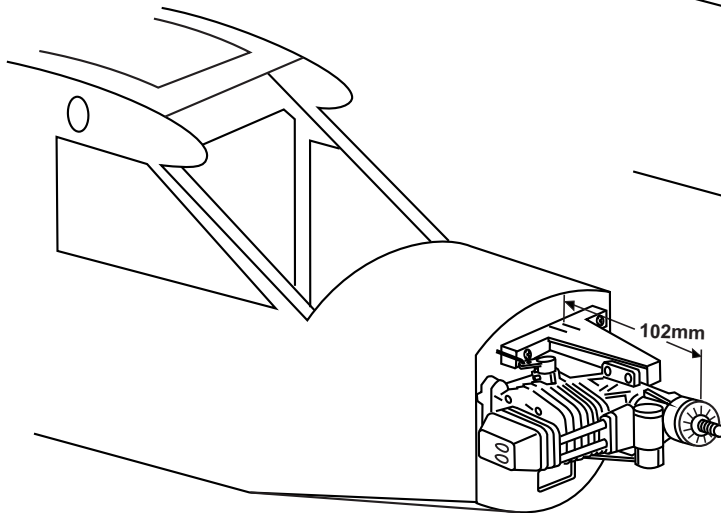

**B** Position the engine on the engine mount beams so the distance from the prop hub to the fire-wall is 102mm/(4"). Using a pencil, mark the engine mounting plate where the four holes are to be drilled. Note: Mark the mounting plate through the engine mounting flanges.

**C** Remove the engine and drill a 3.5mm hole through the beam at each of the four marks made in Step B.

**D** Reposition the engine on the mounting beams, aligning it with the holes drilled in Step 3. Insert one 3x25mm screw through each of the mounting holes. Apply Silicon to each of the 3x25mm screws and firmly secure the engine to the motor mount using four 3mm nut.

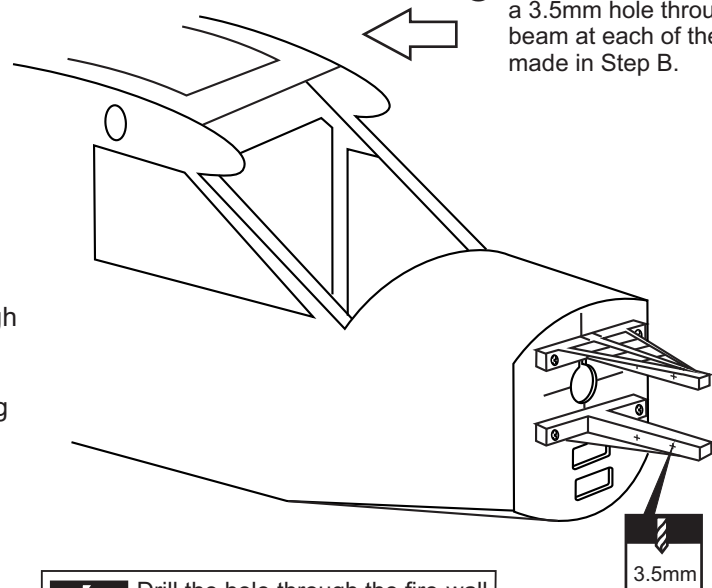

Drill the hole through the fire-wall for the plastic pushrod tube

Note: It may be easier to temporarily remove the throttle arm from the engine to insert the Z bend of throttle push-rod.

Trim the cowling for engine and muffler. Then, position the cowling in place.

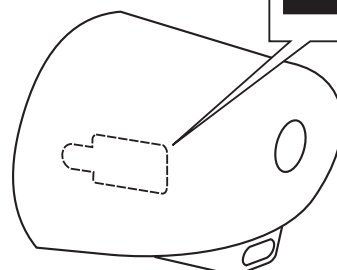
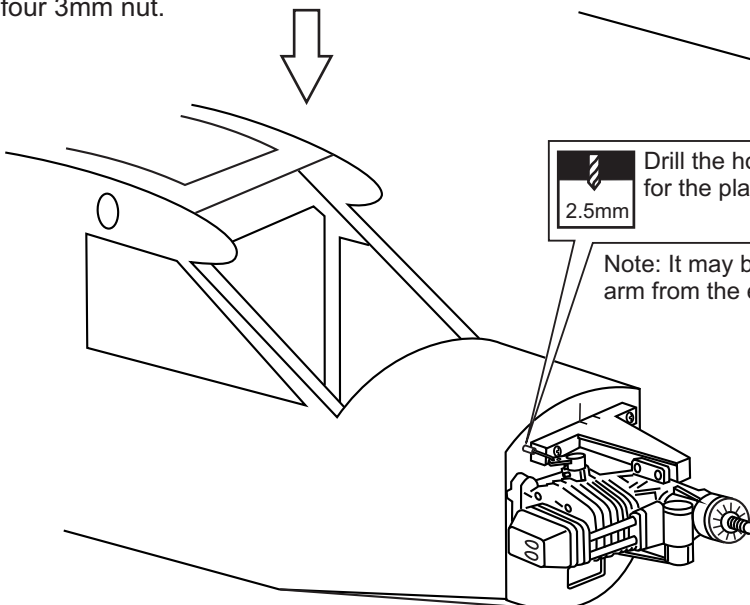

# 2

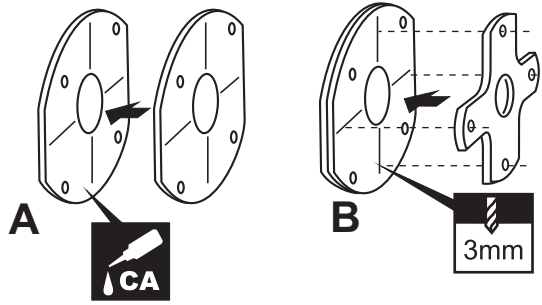

Using a aluminum motor mounting plate as a template, mark the plywood motor mounting plate where the four holes are to be drilled (2). Remove the aluminum motor mounting plate and drill a 1/8" (3mm) hole through the plywood at each of the four marks marked .  
 Note: The aluminum motor mounting included with electric motor set.

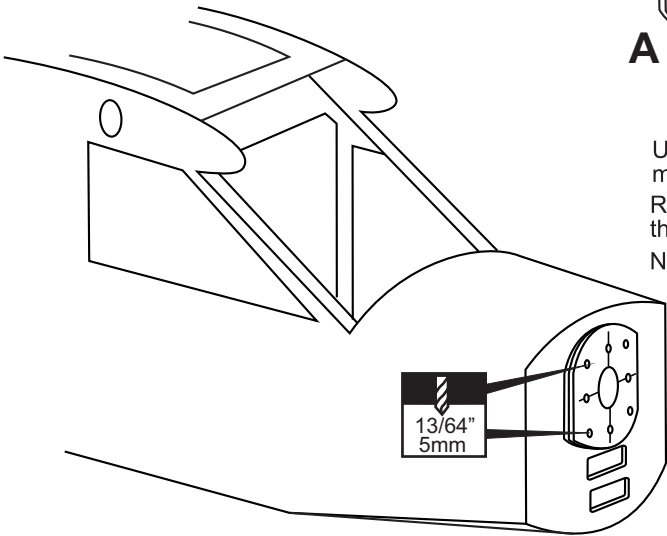

**C** Using a plywood motor mounting plate as a template, mark the fire wall where the four holes are to be drilled . Remove the plywood motor mounting plate and drill a 13/64" (5mm) hole through the fire-wall at each of the four marks marked above.

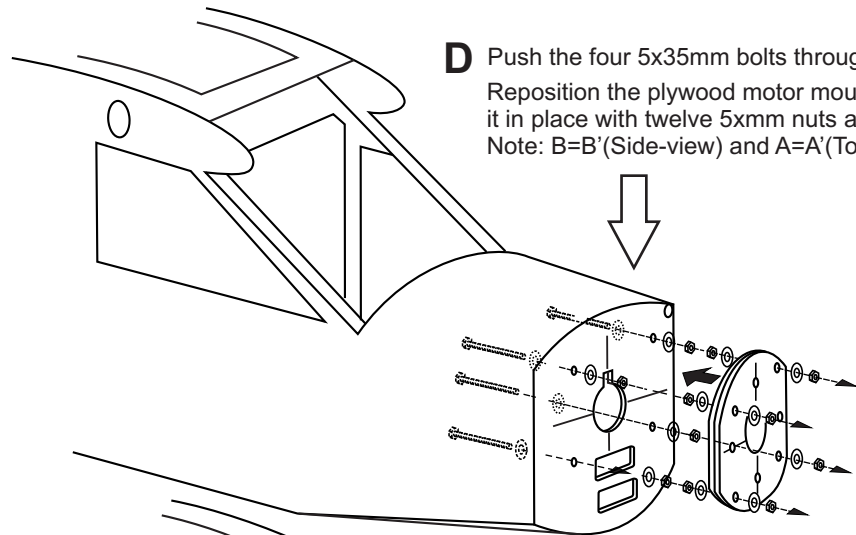

**D** Push the four 5x35mm bolts through the fire-wall as shown (5). Reposition the plywood motor mounting plate and secure it in place with twelve 5xmm nuts and washers (6).  
 Note: B=B' (Side-view) and A=A' (Top-view)

SIDE-VIEW / Seitenansicht

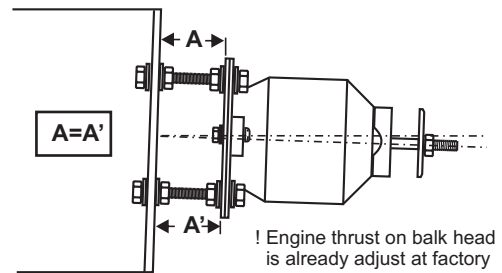
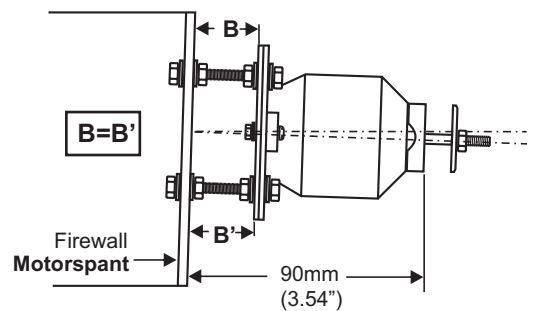

TOP-VIEW / Draufsicht

Attach the aluminum motor mounting plate on to the motor and secure it in place with four screws ( included with motor set).

5x35 screw	5mm washer
X4	X16
5mm nut	
X12	

**Sperrholztrager Platten zusammenkleben, wie gezeigt ausrichten und Locher bohren.**

**Motor nach untenstehendem Schema einbauen.**

**Fur optimale Leistung empfehlen wir folgende Komponenten:**

- Brushless-Motor PICHLER BOOST 60
- Brushless Regler PICHLER XQ-70
- LiPO Akku LEMONRC 3700-5S
- Luftschaube 12\*6 - 13\*8

For maximum performance, we recommended the following:

- Brushless-Motor PICHLER BOOST 60
- Brushless Regler PICHLER XQ-70
- LiPO Battery LEMONRC 3700-5S
- Propeller 12\*6 - 13\*8

# 3

2.5x8mm screw

 .....3

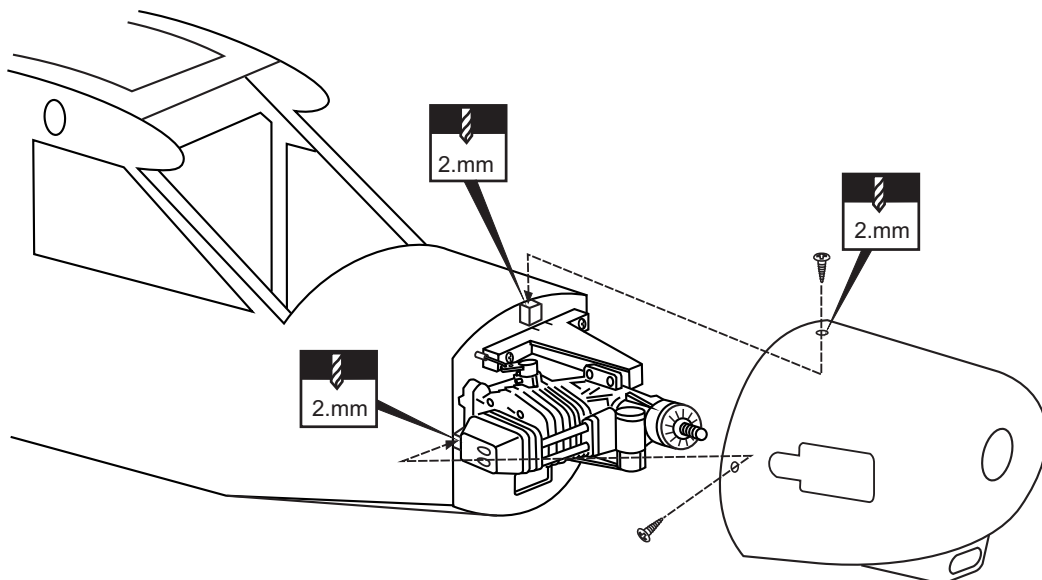

# 4

Cut two slots (3x7mm and 3mm deep) along the trailing edge of the horizontal stabilizer.

TOP VIEW / Draufsicht

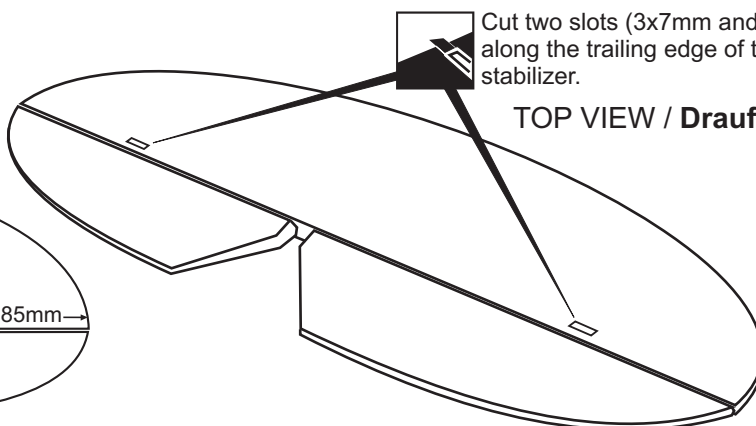
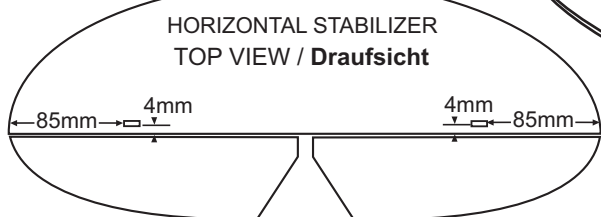

# 5

**5A** Full the elevator out of the horizontal stabilizer.

Cut away only the film both side



**5B**

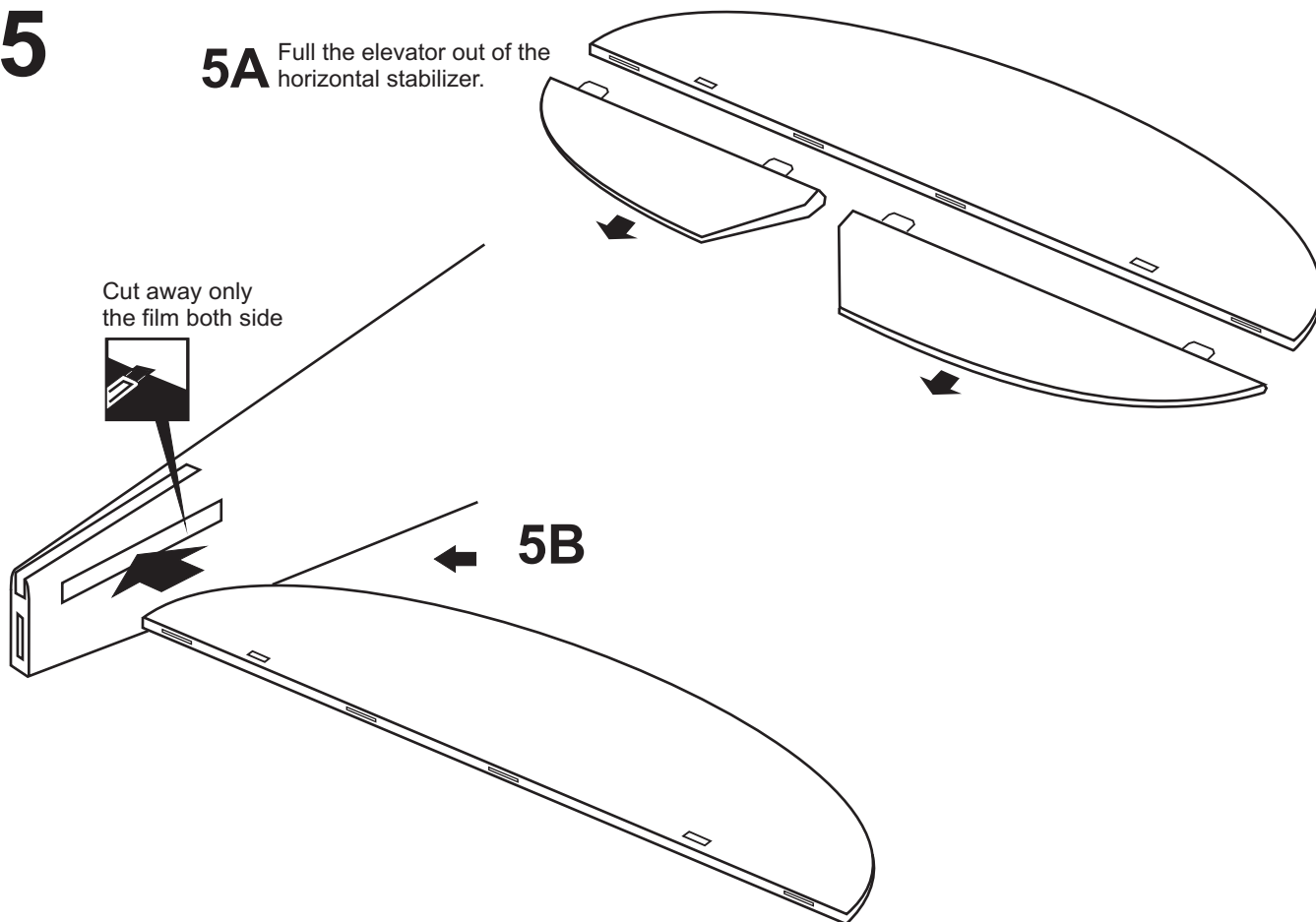

# 6

**6A** When you are satisfied with the alignment, use a pencil to trace around the top and bottom of the stabilizer where it meets the fuselage.

Cut away only the covering both side

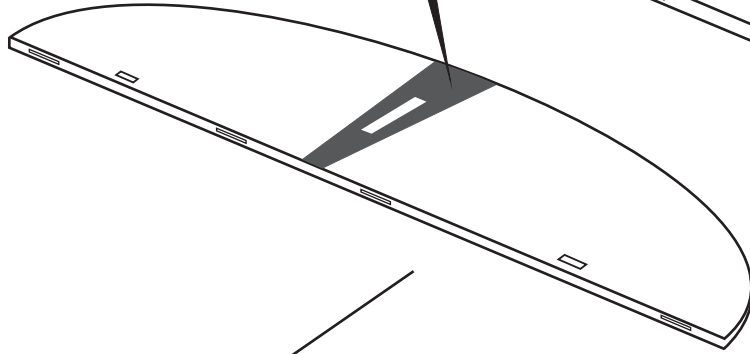

**6B** Remove the horizontal stabilizer from the fuselage. Using the sharp hobby knife, carefully cut away the covering inside the lines which were marked above.

\* **WARNING:** When removing any covering from the airframe, please ensure that you secure the cut edge with CA or similar cement. This will ensure the covering remain tight.

**6C** Install the horizontal stabilizer into the fuselage and adjust the alignment as described in step 5B. Secure the horizontal stabilizer in place using CA glue.

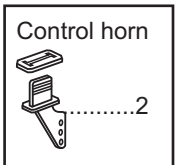
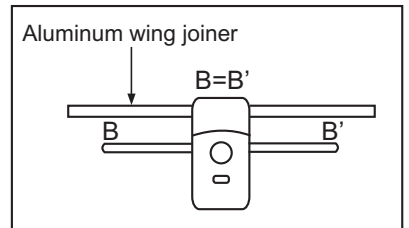
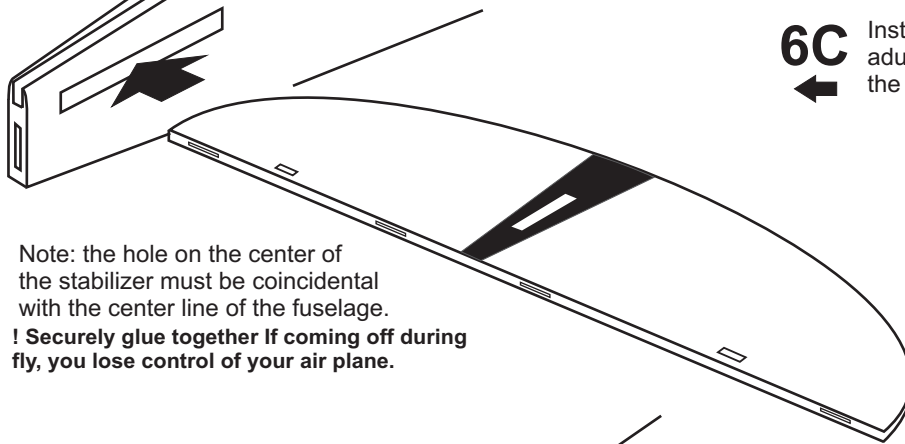

Note: The slots for the control horn installation are pre-cut at factory.

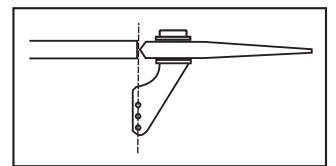

# 6D

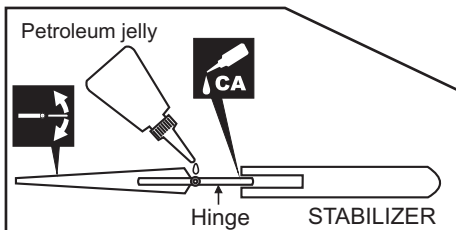
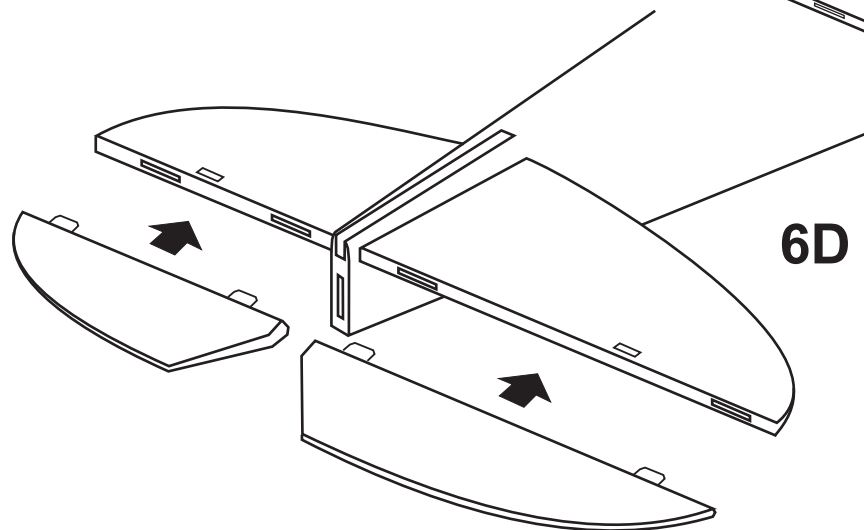

Apply a thin layer of machine oil or petroleum jelly to only the pivot point of the hinges on the elevator, then push the elevator and its hinges into the hinge slots in the trailing edge of the horizontal stabilizer. There should be a minimal hinge gap. When satisfied with the alignment, hinge the elevator to the horizontal stabilizer using CA glue.

# 6E

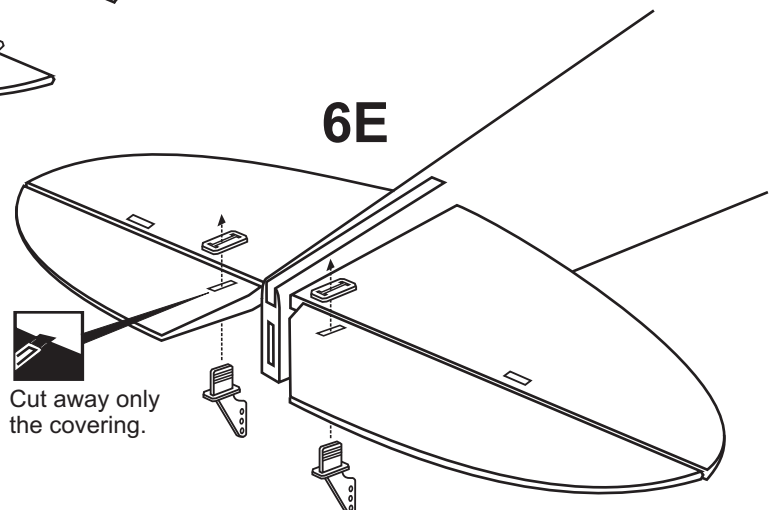

# 7

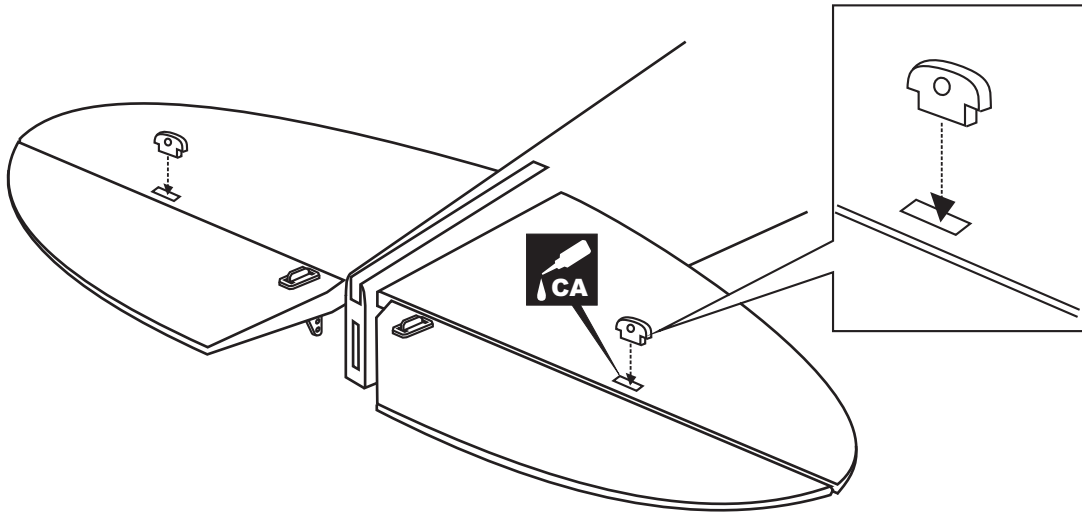

# 8

Cut a slots (3x7mm and through both the covering and balsa wood) along the trailing edge of the vertical stabilizer.

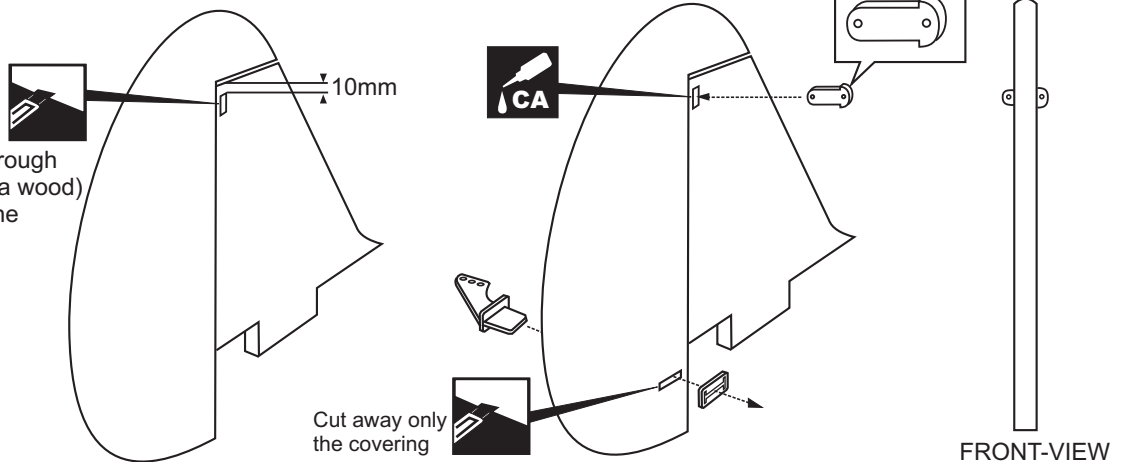

Trial fit the vertical stabilizer in place. Check the alignment of the vertical stabilizer.

If the parts will join, but with a gaps, sand or trim the parts a little at a time until the parts meet exactly with no gaps.

When you are satisfied with the alignment, use a pencil to trace around the left and right of the stabilizer where it meets the fuselage.

Remove the vertical stabilizer from the fuselage. Using the sharp hobby knife, carefully cut away the covering inside the lines which were marked above.

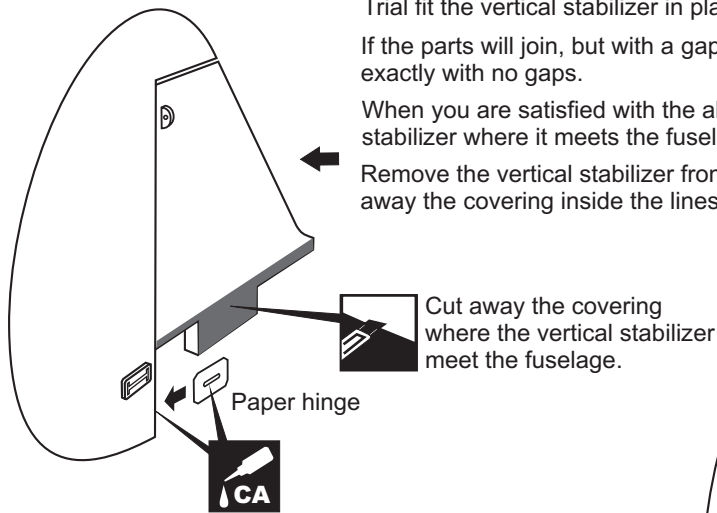

Cut away the covering where the vertical stabilizer meet the fuselage.

Install the vertical stabilizer into the fuselage and adjust the alignment. Secure the vertical stabilizer in place using CA glue.

**! Securely glue together** If coming off during fly, you lose control of your air plane.

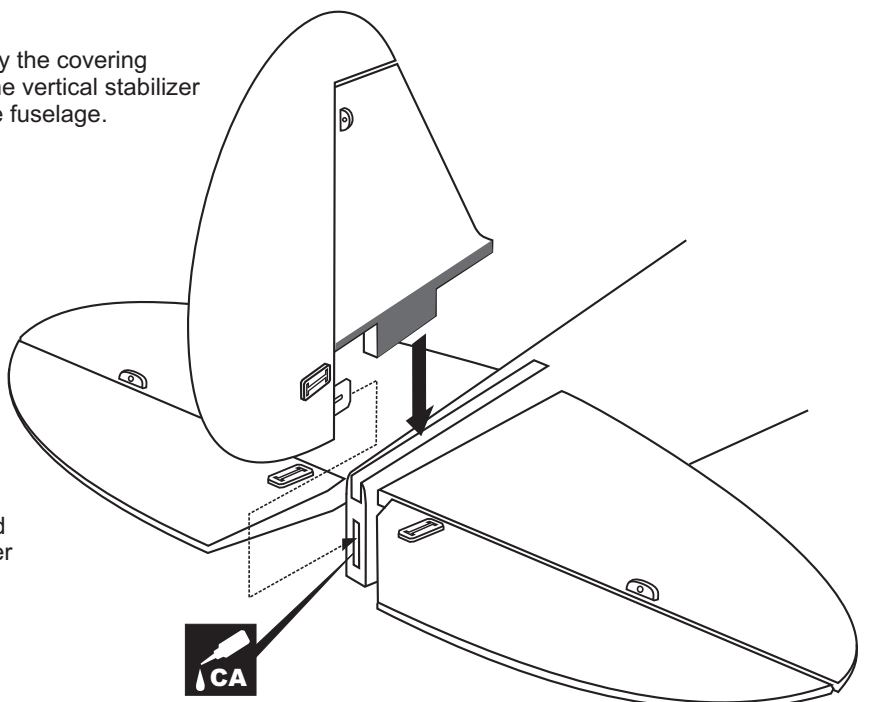

# 9

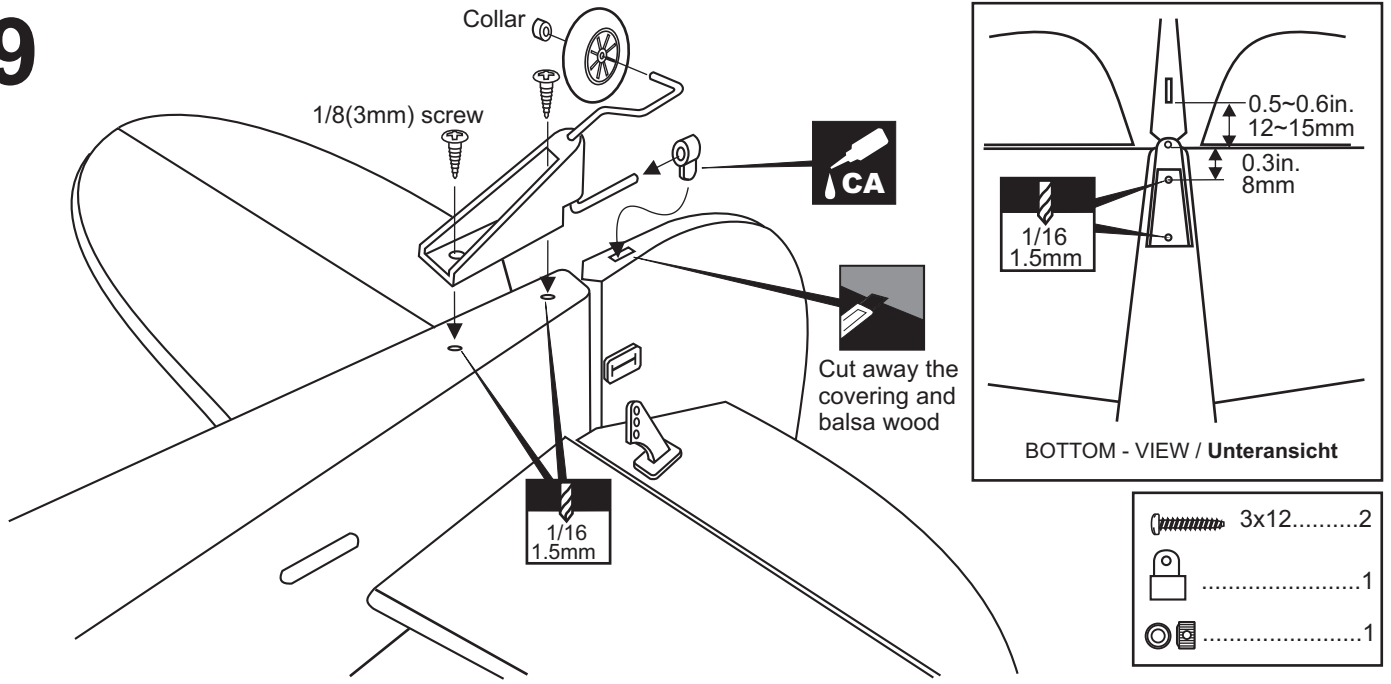

# 10

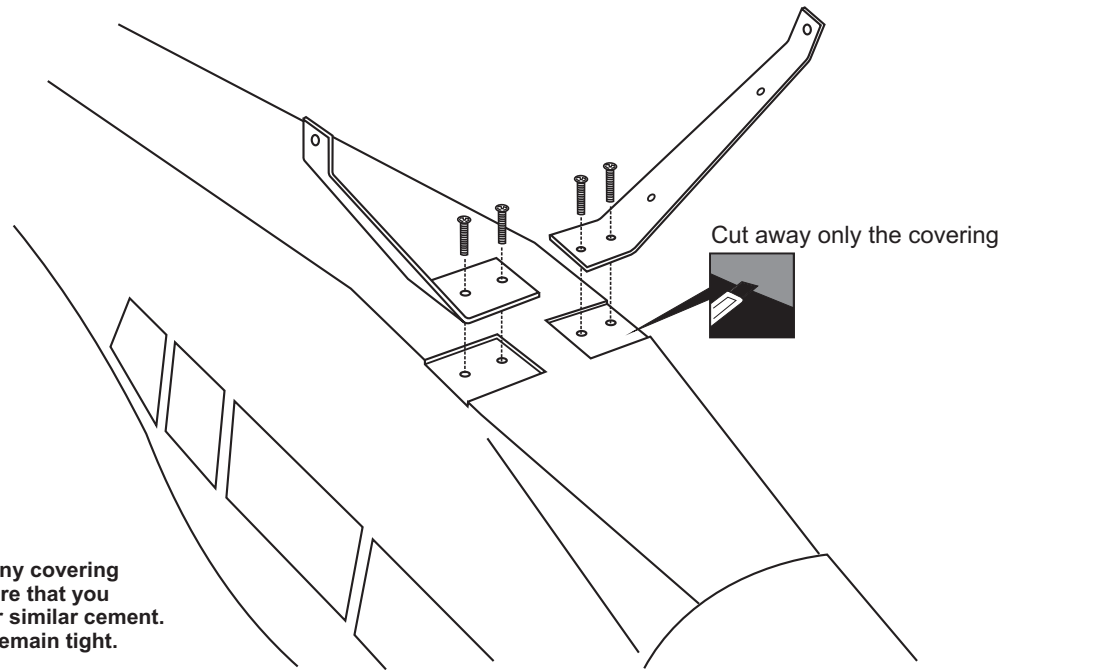
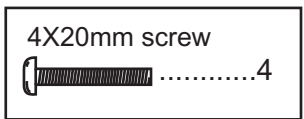

**\* WARNING:** When removing any covering from the airframe, please ensure that you secure the cut edge with CA or similar cement. This will ensure the covering remain tight.

# 11

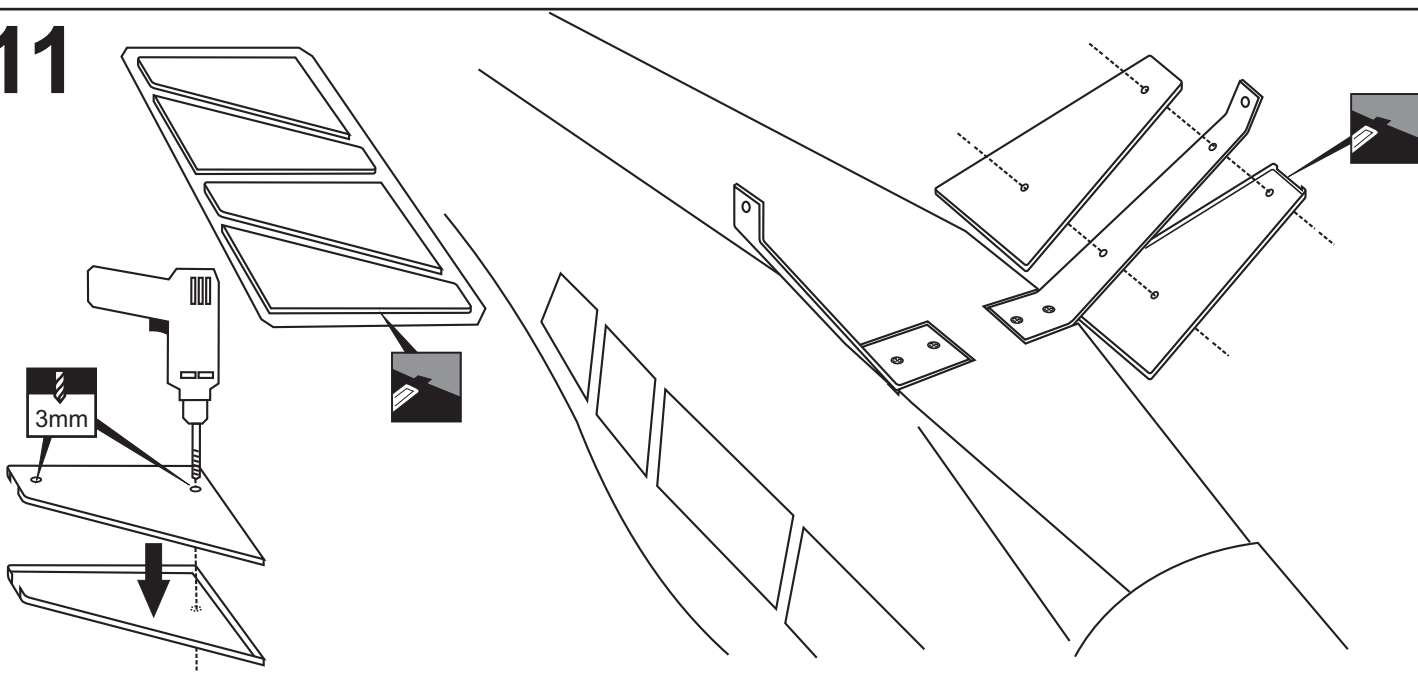



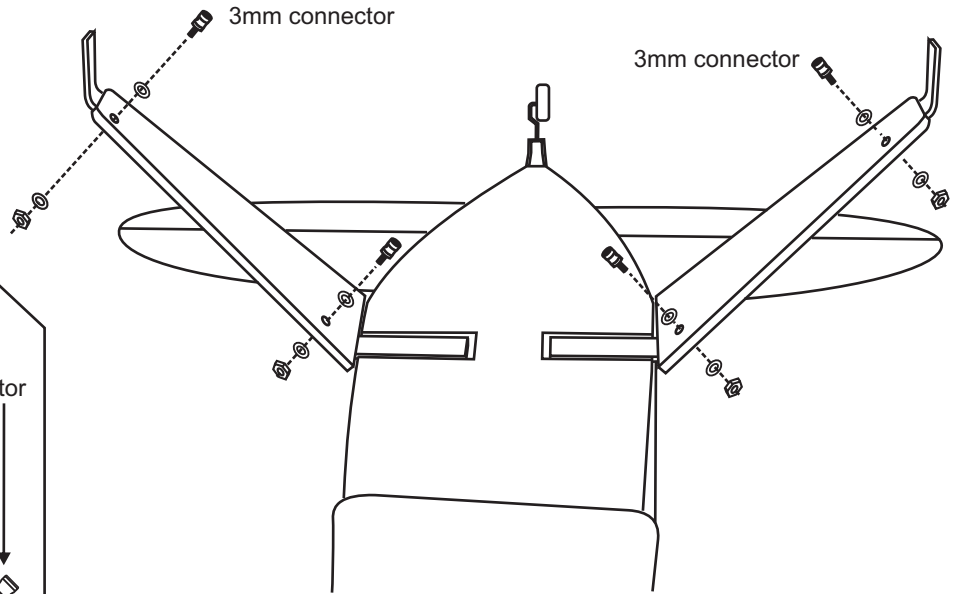
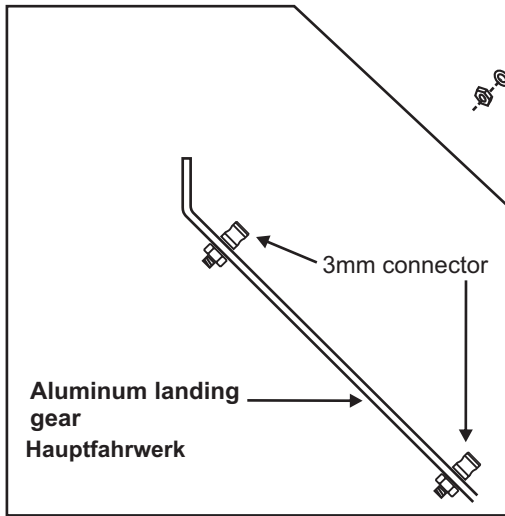

# 12

Connector  
 .....4



# 13

4X50mm screw  
 .....2  
 4mm nut-washer  

BOTTOM - VIEW / Unteransicht

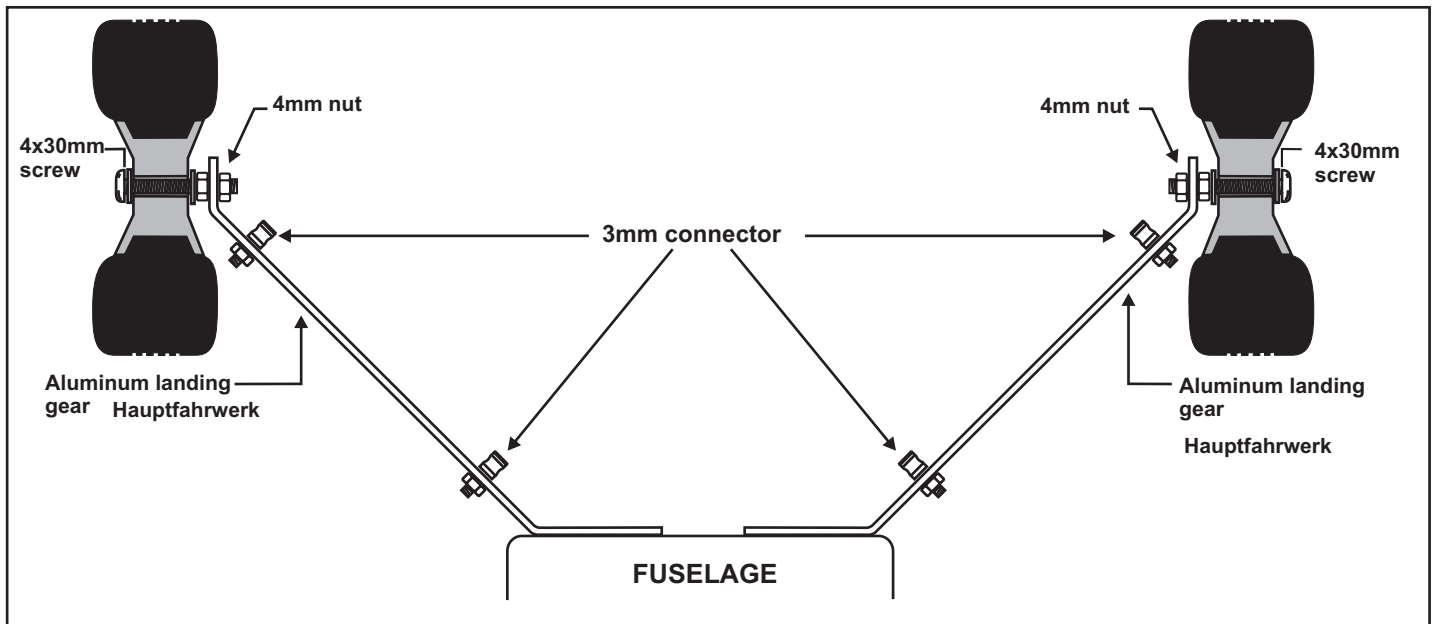
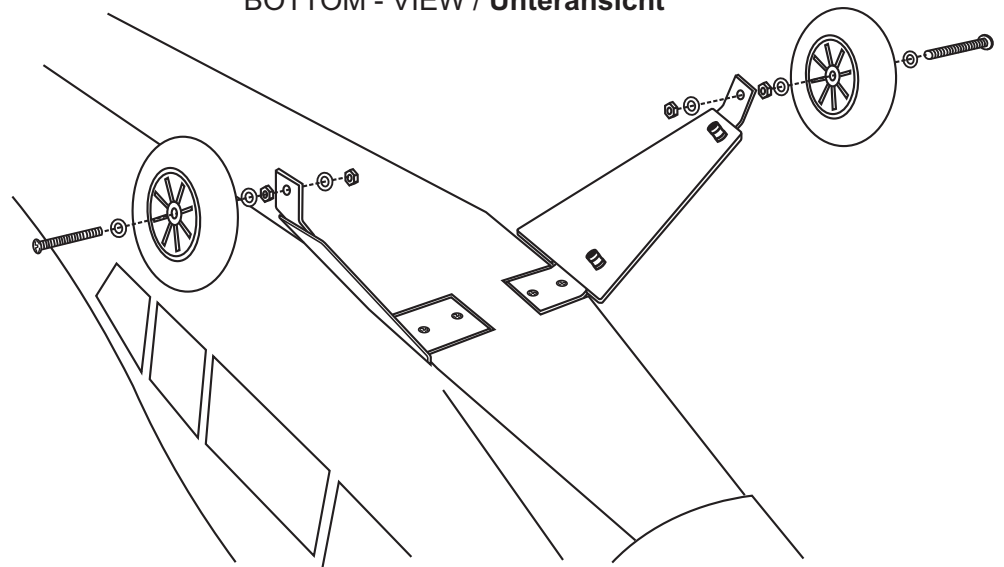

# 14

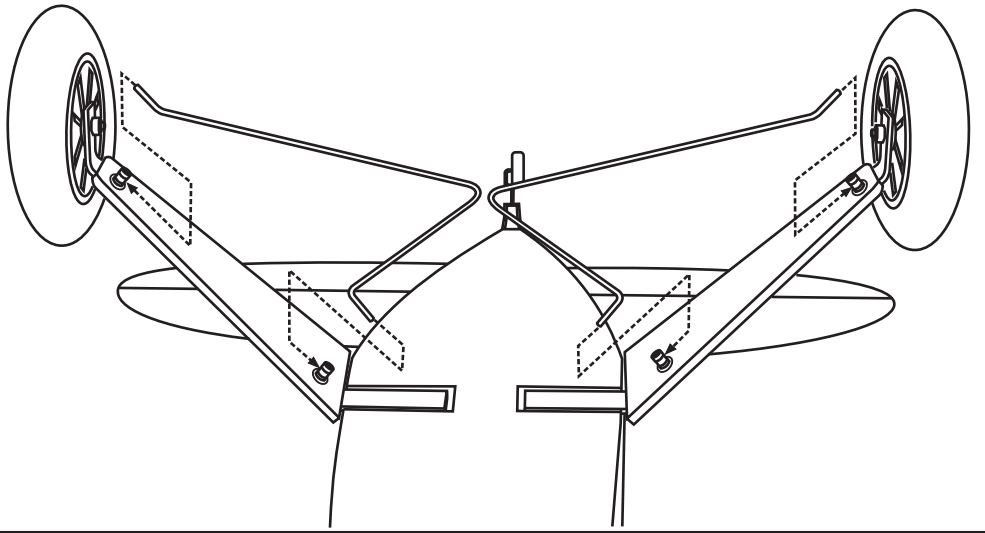
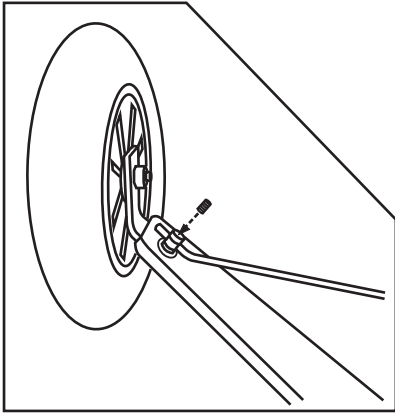

# 15

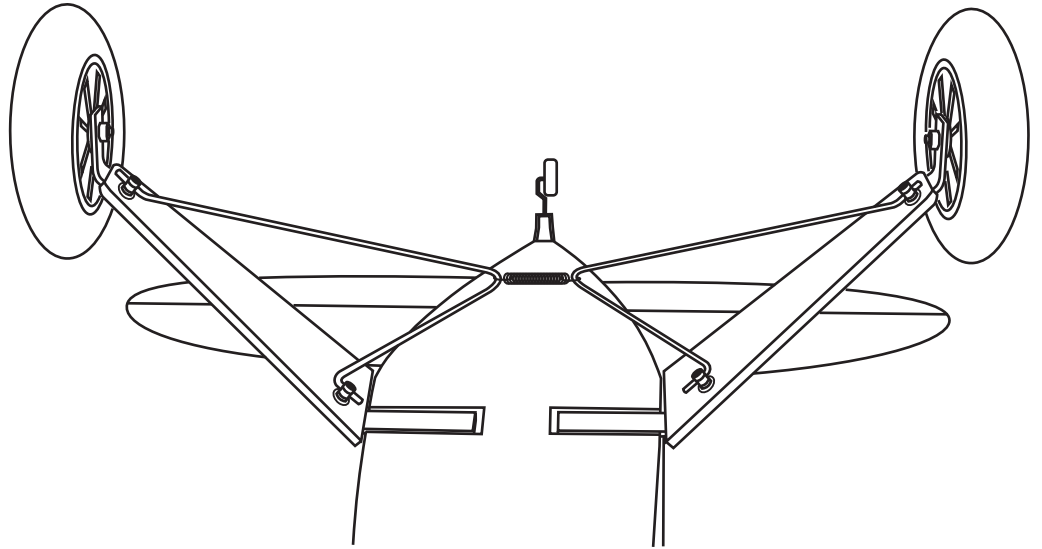
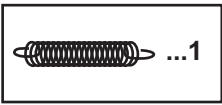

# 16

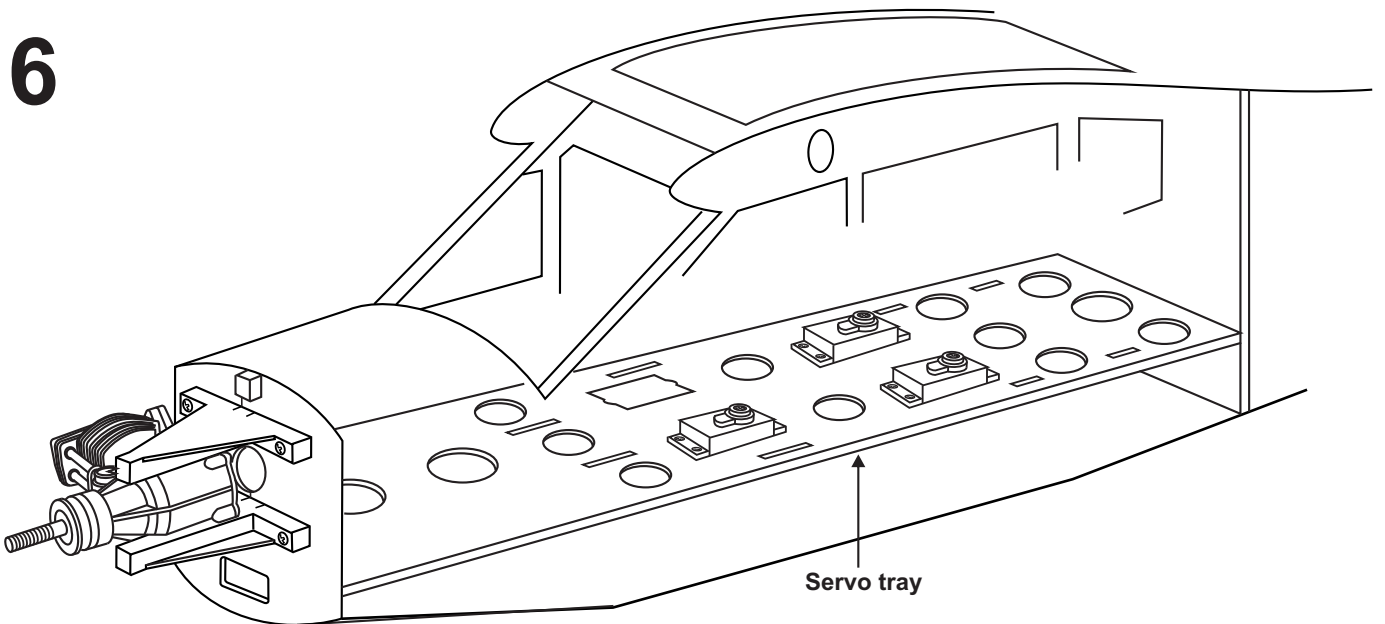

TOP VIEW

FRONT  
←

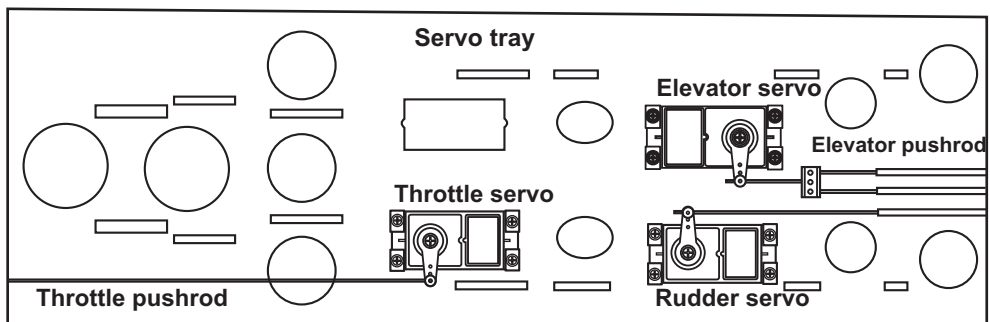

# 17

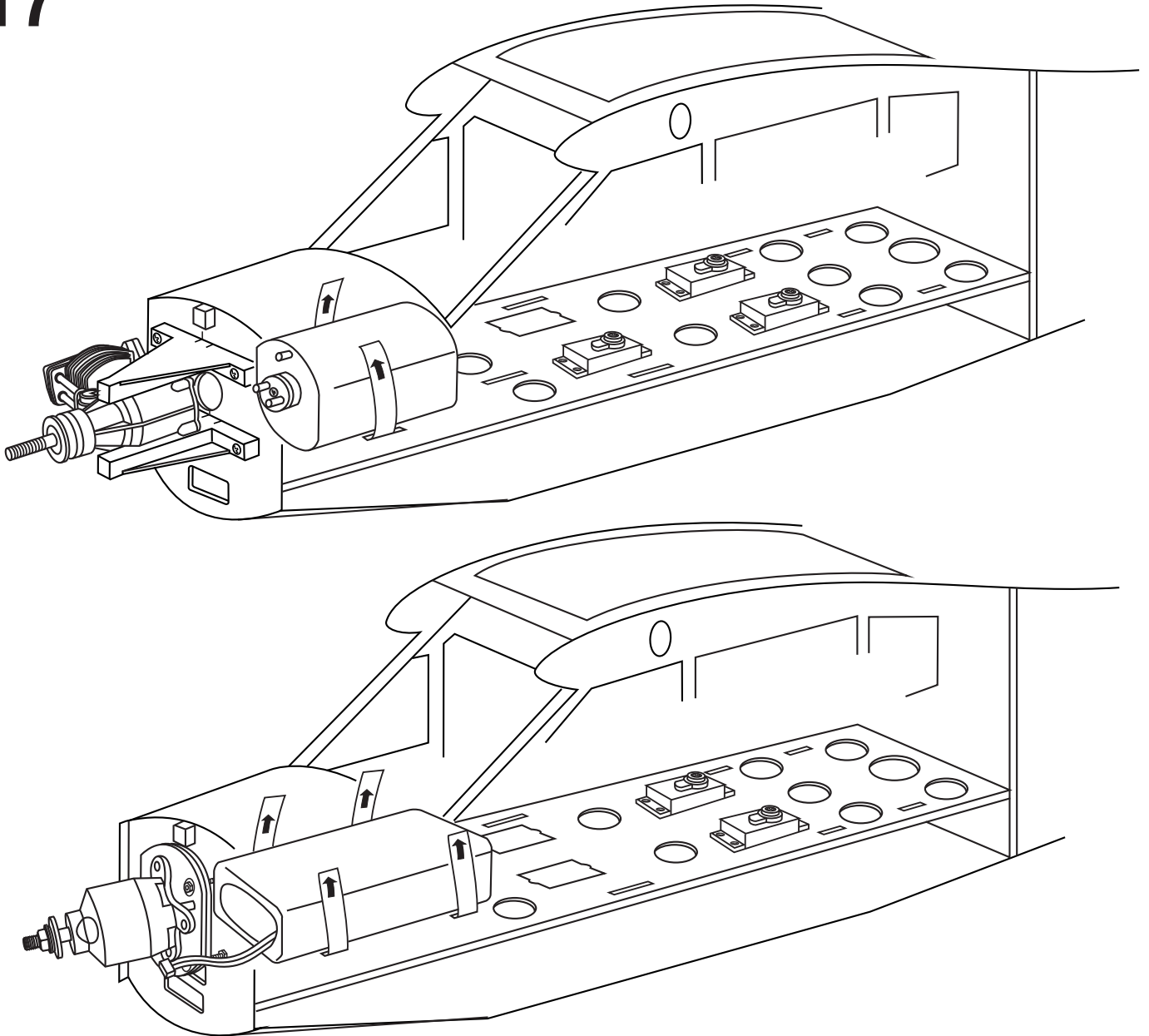

# 18

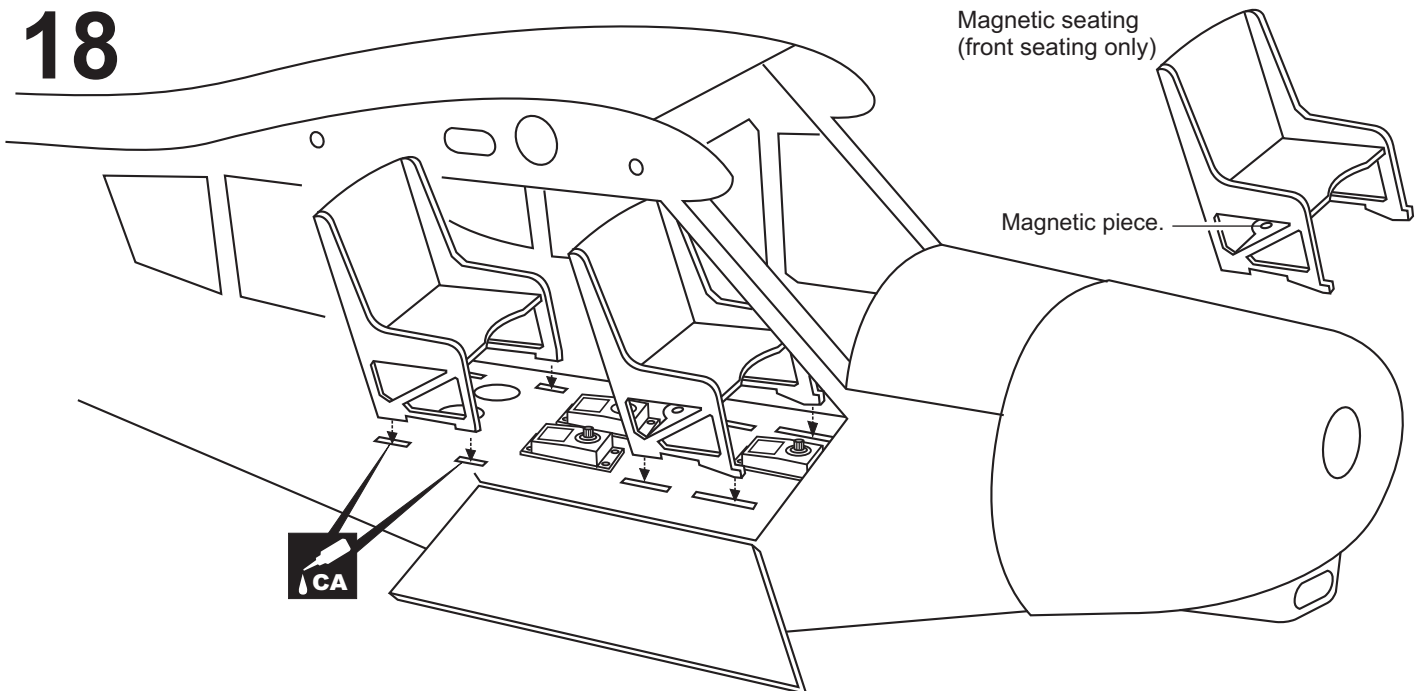

# 19

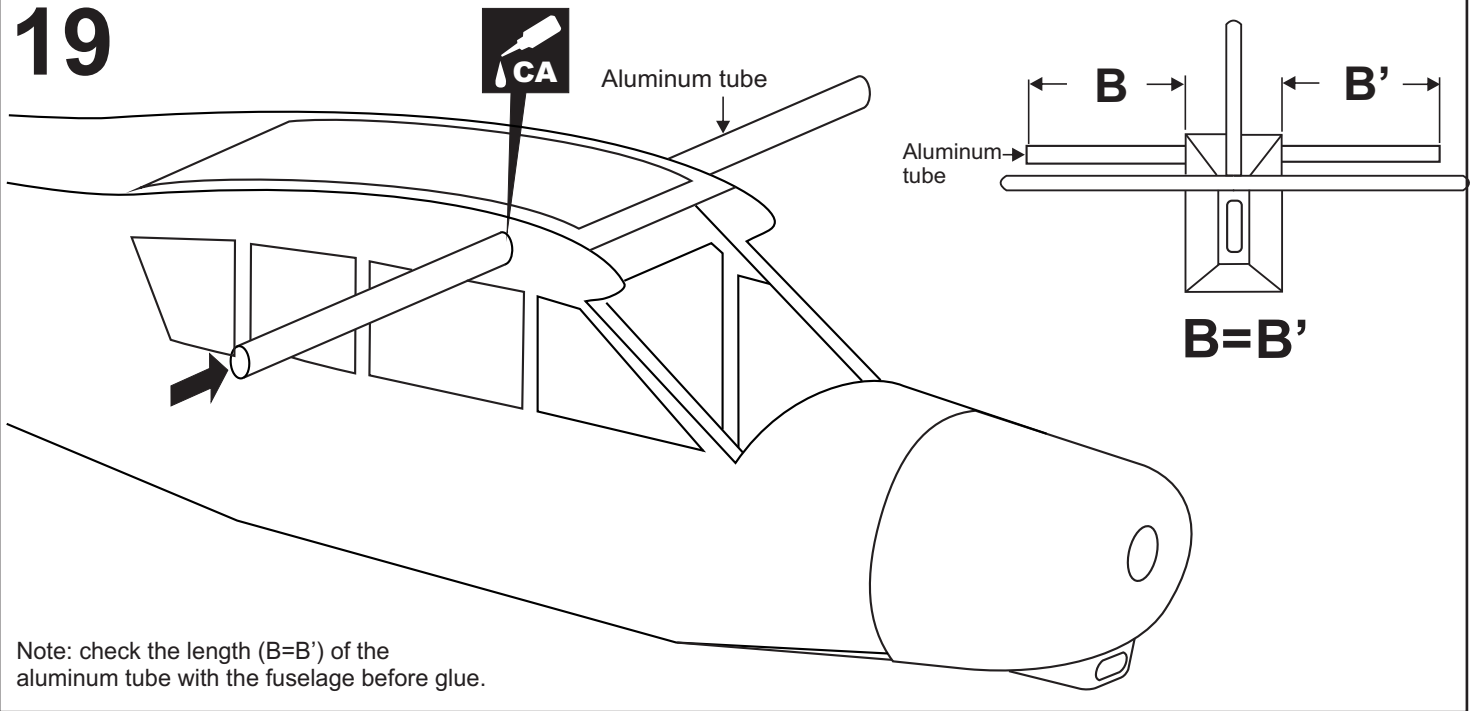

# 20

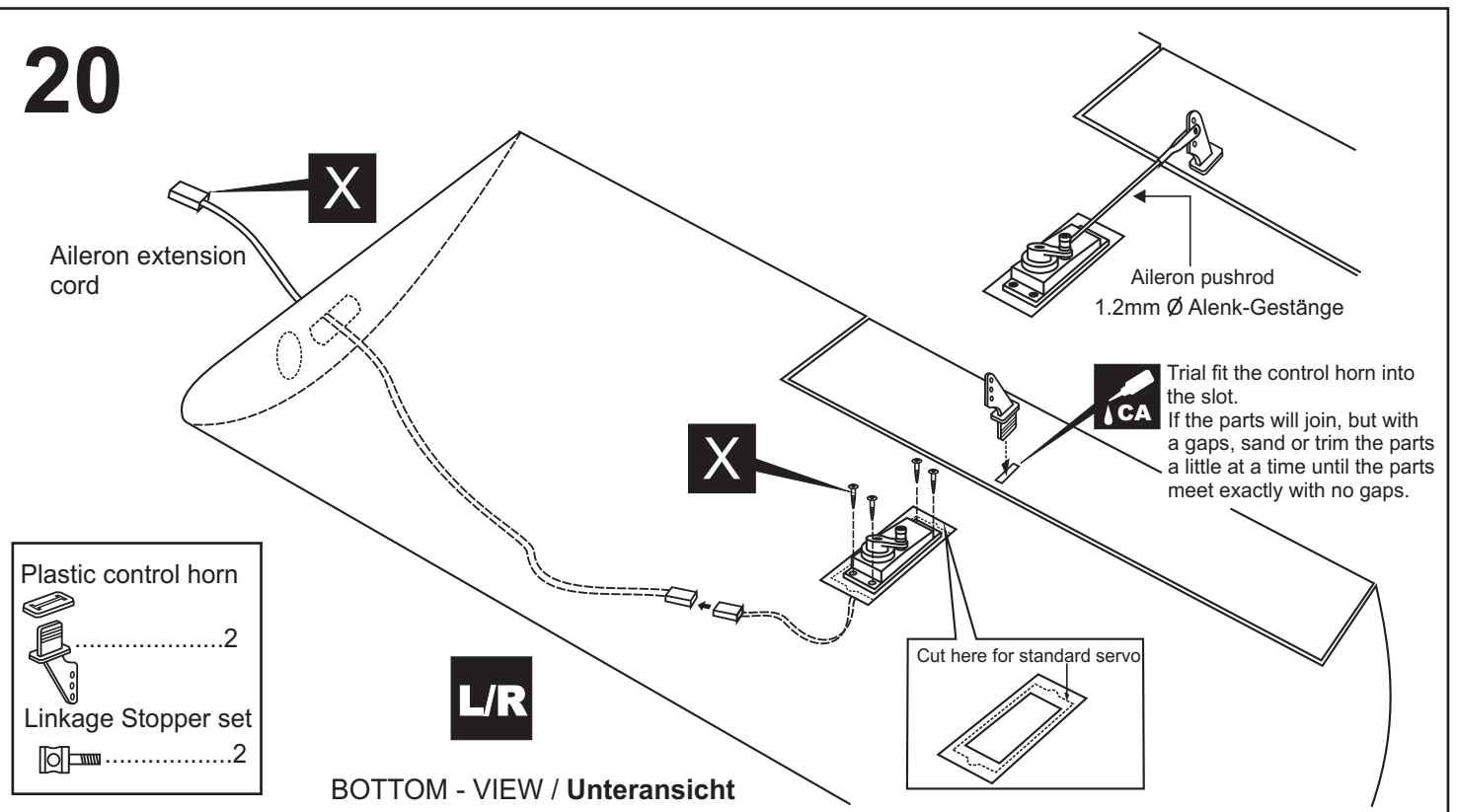

# 21

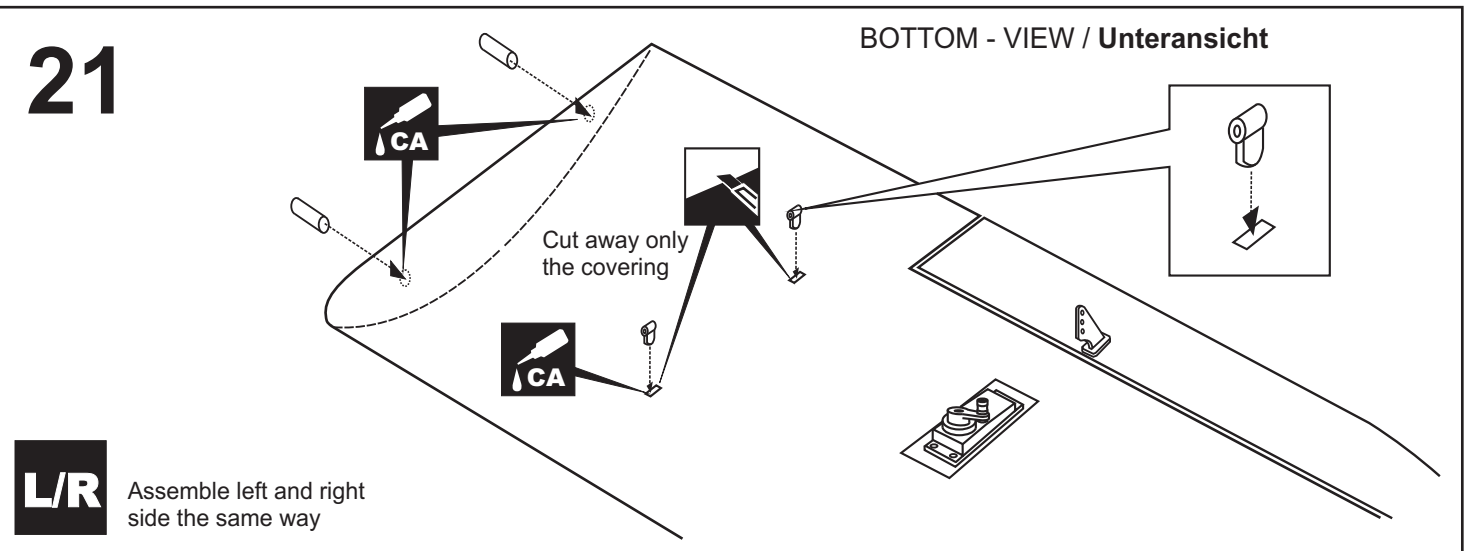

# 22

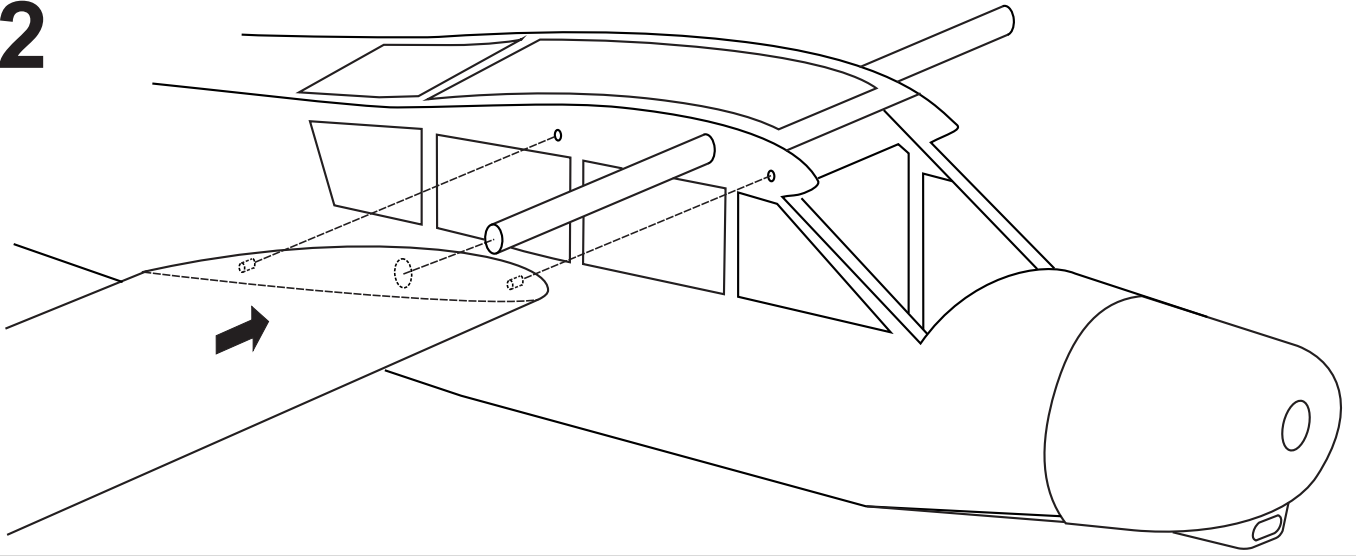

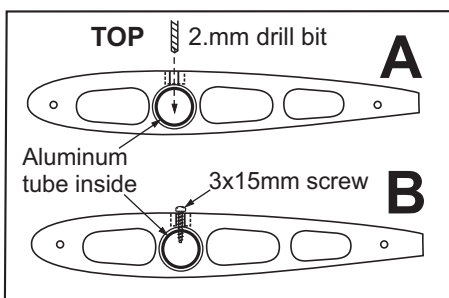
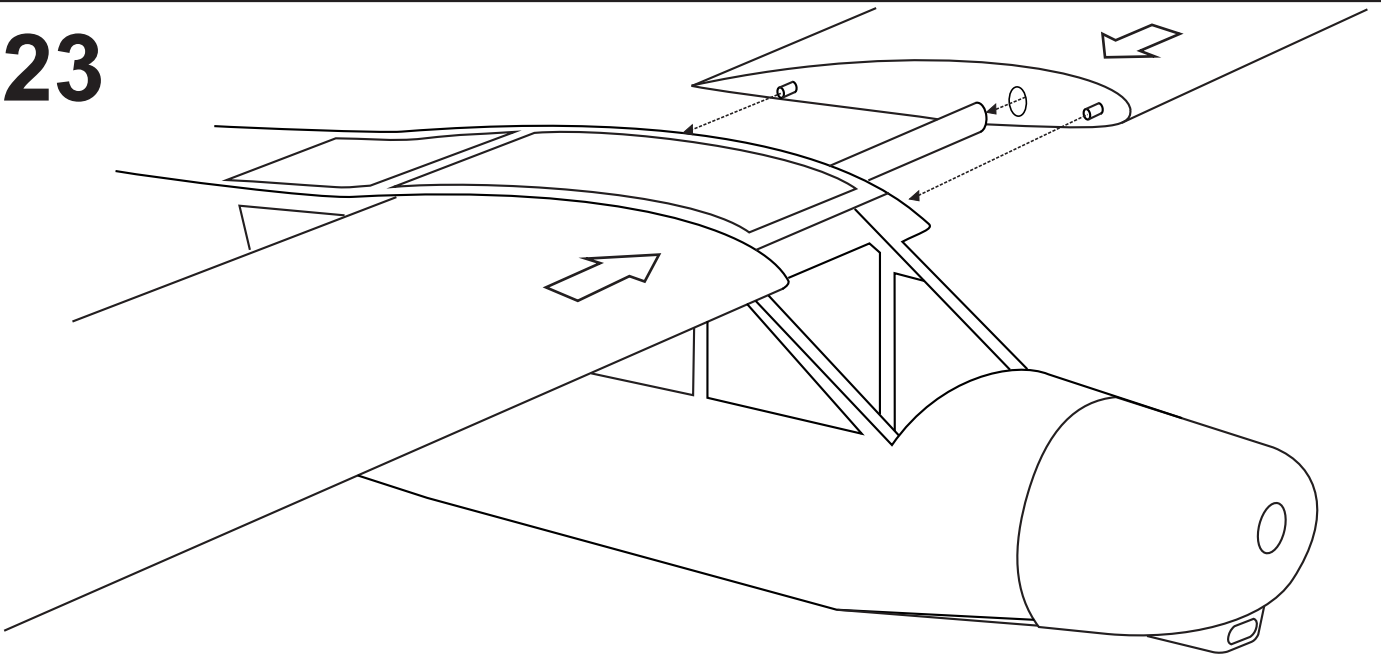

# 23

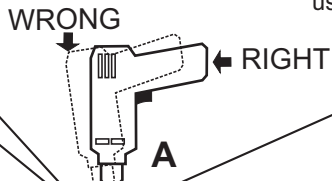

Note: The hole on the surface of the top of the wing are pre-drilled at factory.

Secure the wing in place using 3x15mm screw.



3x15mm screw  
 .....2

# 24

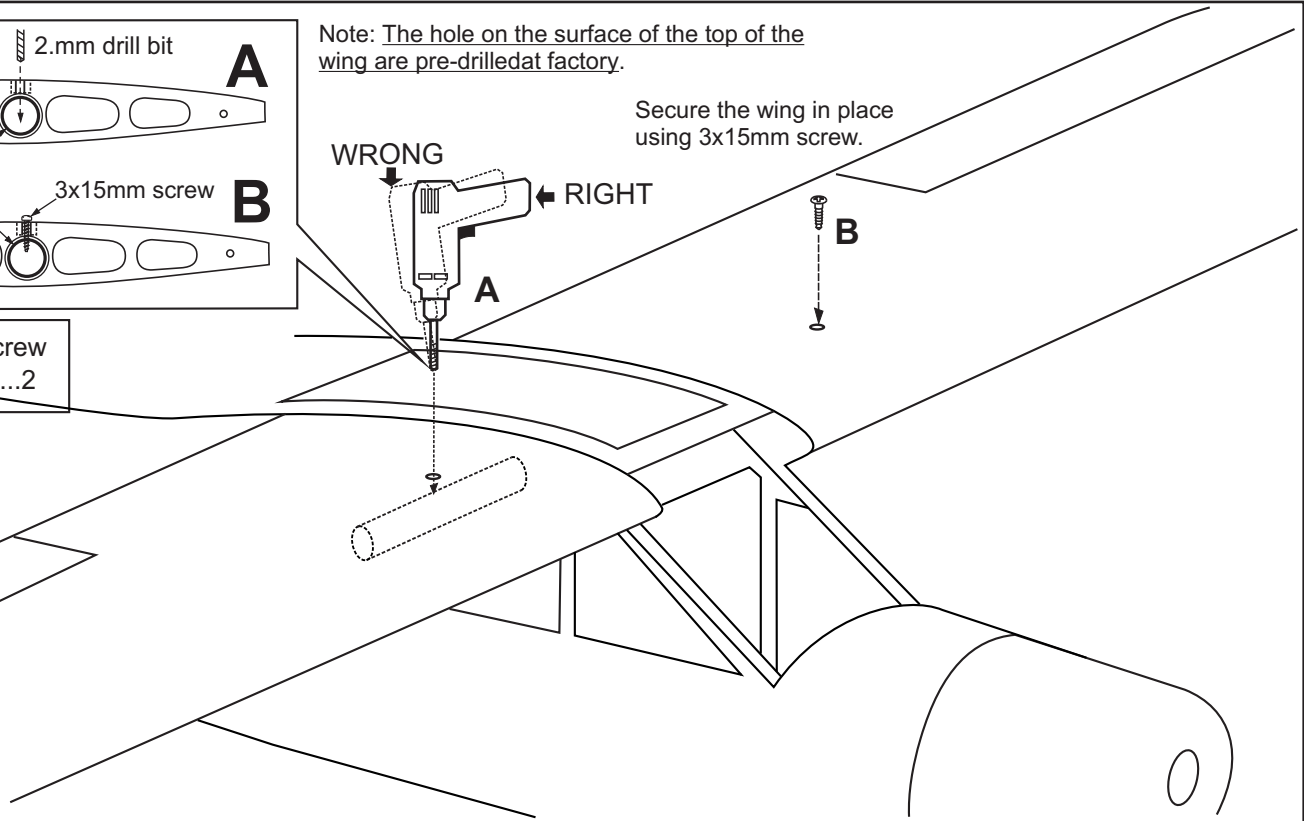

# 25

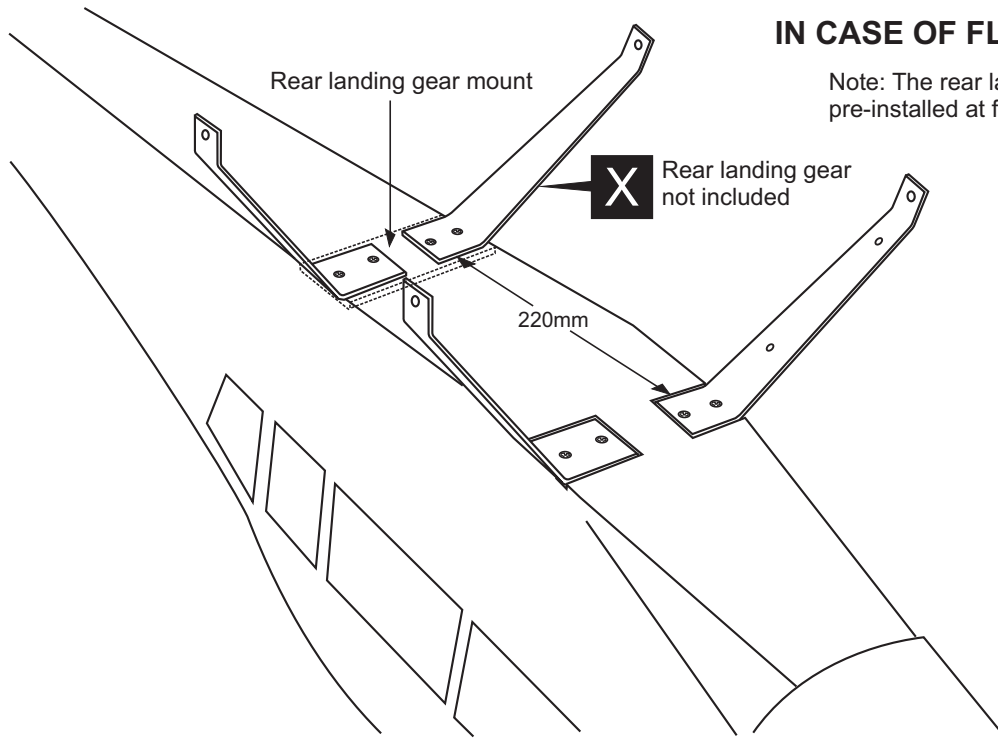

## IN CASE OF FLOATING USING

Note: The rear landing gear mount is pre-installed at factory



BOTTOM - VIEW / Unteransicht

# 26

- 3x15mm screw  .....6
-  .....4

Cut away only the covering

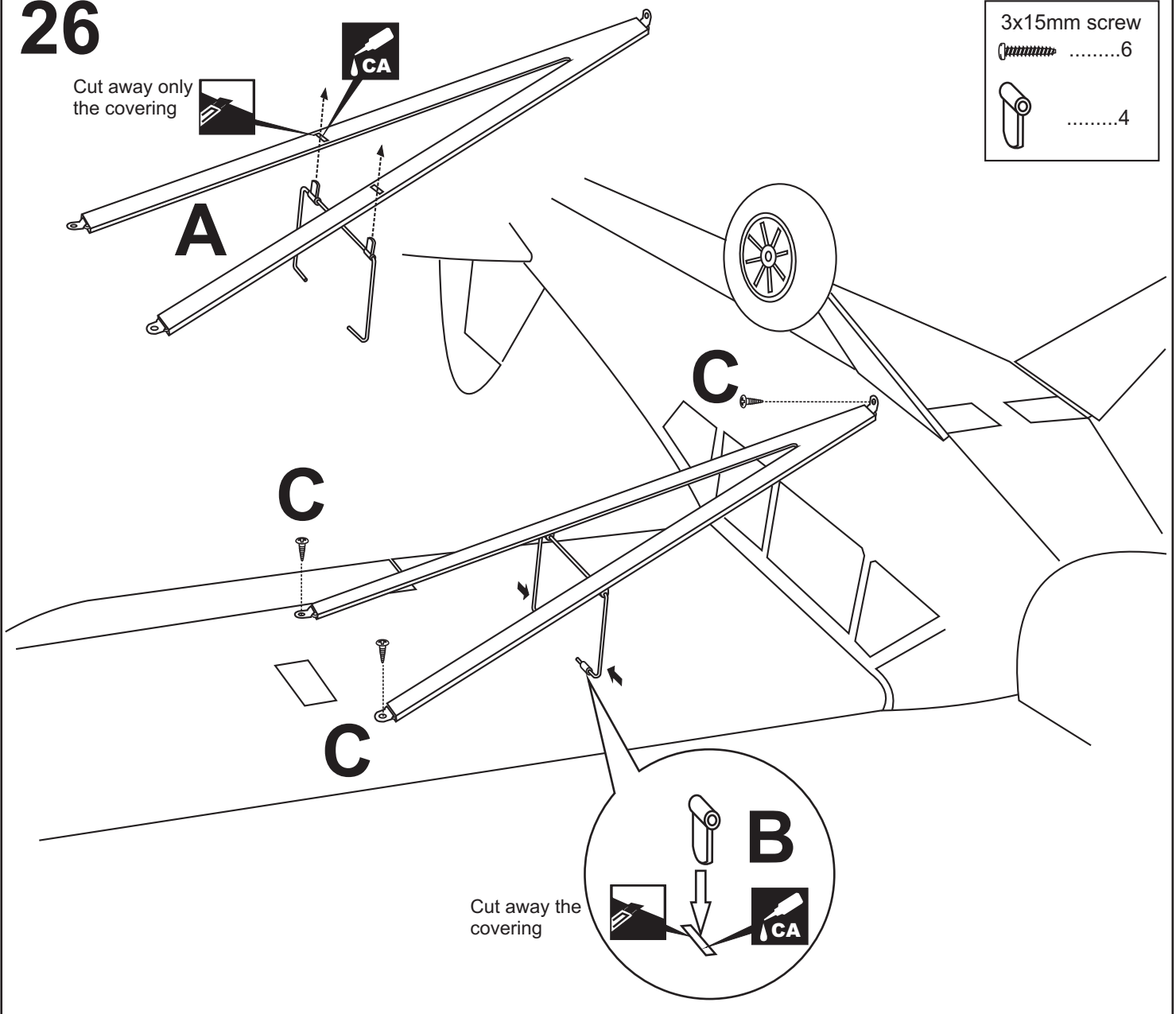

Cut away the covering

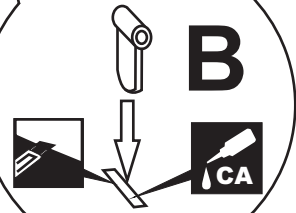

# 27

0.5mm dia. Cable



...1 roll

2mm metal tube

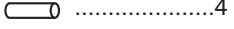

.....4

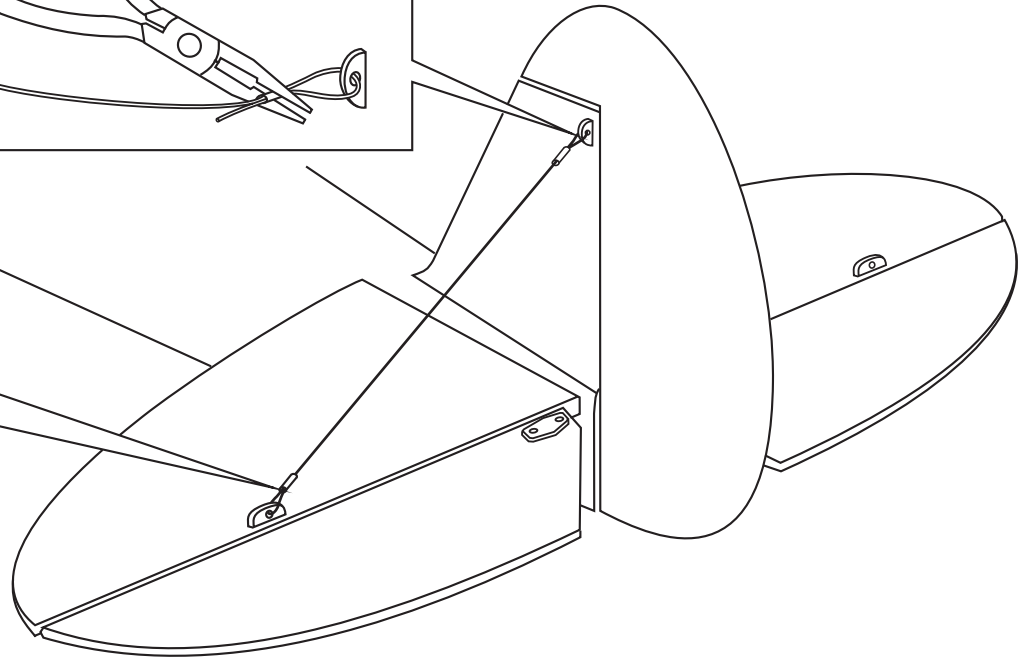
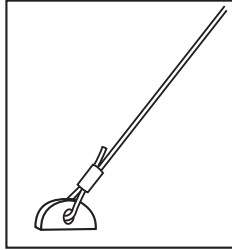
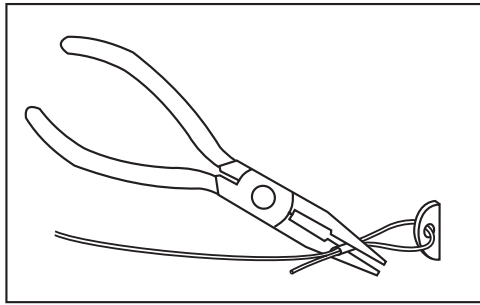

# 28

## VQA086 (L4 GrassHopper) version

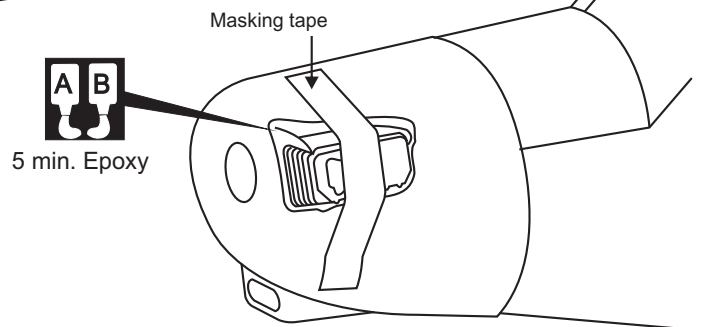
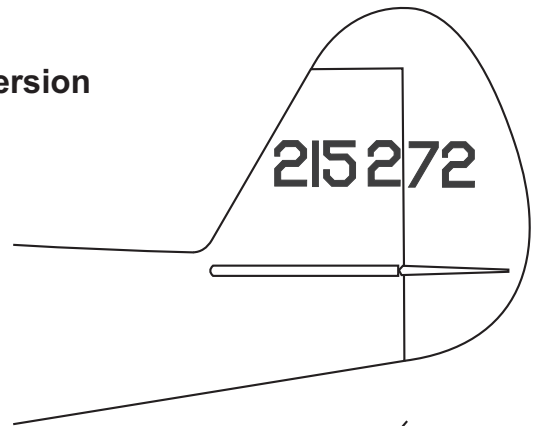
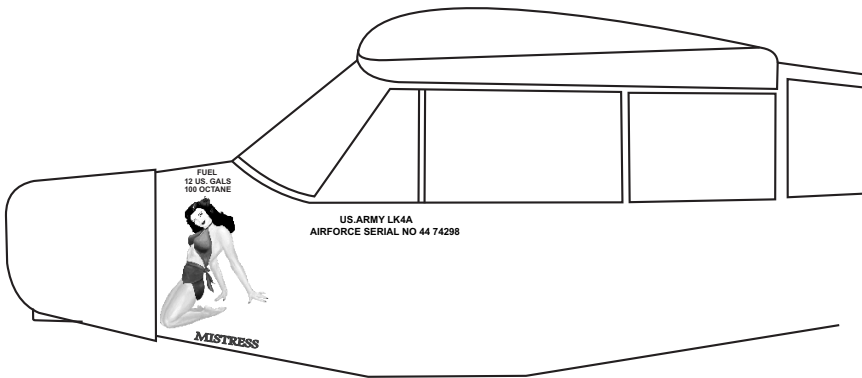

Note: Cut out the stickers and apply them in the proper area. Do not peel the backing paper off all at once. Peel off one corner of the backing and cut off with scissors. Arrange sticker on model and when satisfied adhere the corner without backing. Carefully peel back the rest of the backing while at the same time adhering the rest of the sticker.

Try not to make air bubbles, if there are some, carefully puncture sticker (center of bubble) but not model surface with the tip of the knife or sharp pin and squeeze out the air. At curves stretch sticker and apply a little heat so that no creases occur. Cut off the excess that is produced.

# 29

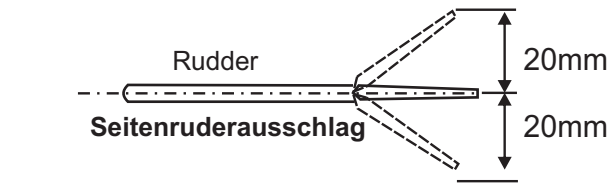

← 65 ~ 70mm →

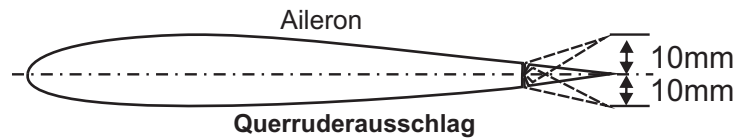
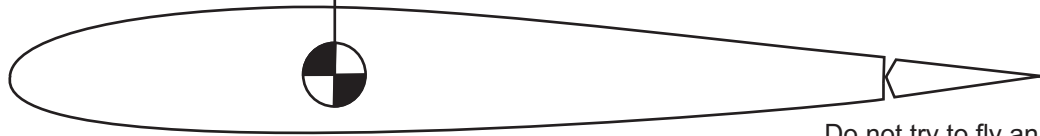

Do not try to fly an out-of balance model!

**Überprüfen Sie vor dem Flug den Schwerpunkt.**

**IMPORTANT:** Please do not clean your model with pure alcohol, only use liquid soap with water or use glass cleaner to clean on surface of your model to keep the colour not fade.

**WARNING !**

Do not put in a large-than recommended engine. A bigger engine does not necessarily mean better performance.

All details are subject to change without notice !

**Technische Änderungen und Irrtümer vorbehalten !**