

**20cc  
Gas Engine  
Glow 120 4T**

**Pilatus  
Porter**

**PC-6**

**RADIO CONTROL MODEL / RC FLUGMODELL**

**BUILDING INSTRUCTIONS / MONTAGEANLEITUNG**



**SPECIFICATIONS**

Wingspan	85.4 in.
Length	59.8 in.
Flying weight	14.4 lbs
Gas Engine	20cc
Radio	6 Channel / 8 servos

**Technische Daten**

Spannweite	2.170mm
Länge	1.520mm
Fluggewicht	4.500g
Verbrennerantrieb	20cc
Fernsteuerung	7 Kanal / 8 Servos

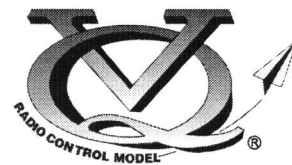

**WARNING!** This radio controlled model is NOT a toy. If modified or flown carelessly it could go out of control and cause serious human injury or property damage. Before flying your airplane, ensure the air field is spacious enough. Always fly it outdoors in safe areas and seek professional advice if you are unexperienced.

**ACHTUNG!** Dieses ferngesteuerte Modell ist KEIN Spielzeug! Es ist für fortgeschrittene Modellflugpiloten bestimmt, die ausreichende Erfahrung im Umgang mit derartigen Modellen besitzen. Bei unsachgemäßer Verwendung kann hoher Personen- und/oder Sachschaden entstehen. Fragen Sie in einem Modellbauverein in Ihrer Nähe um professionelle Unterstützung, wenn Sie Hilfe im Bau und Betrieb benötigen. Der Zusammenbau dieses Modells ist durch die vielen Abbildungen selbsterklärend und ist für fortgeschrittene, erfahrene Modellbauer bestimmt.

**REQUIRED FOR OPERATION (Purchase separately)**  
**BENÖTIGTE KOMPONENTEN FÜR DEN ABFLUG (Nicht enthalten)**

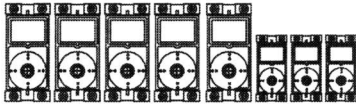
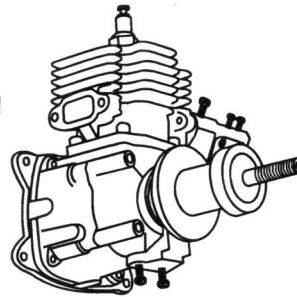
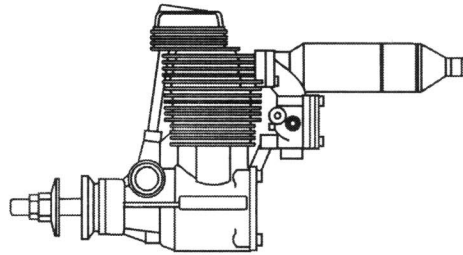
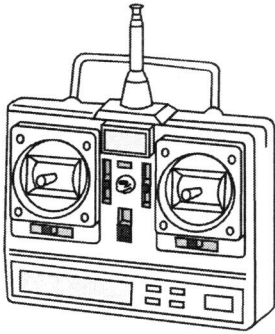

Minimum 7 channel radio for airplane with 5 standard servos and 3 mini servos  
 Flapx2 standard servo - Aileronx2 standard servo  
 Rudderx1 standard servo - Elevatorx2 mini servo  
 Motorx1 mini servo

Glow 120 4T Engine

Gas Engine: 20cc

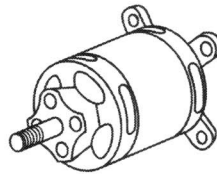

900 - 1.000Watts  
Brushless Motor

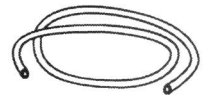

Nylon tube

**GLUE (Purchase separately)**



Silicon sealer

Cyanoacrylate  
Glue  
Klebstoff



Epoxy Glue (5 minute type)  
Epoxy-Klebstoff (5min-Typ)



Epoxy Glue (30 minute type)  
Epoxy-Klebstoff (30min-Typ)

**TOLLS REQUIRED (Purchase separately)**

Hobby knife 

Phillip screw driver 

Hex Wrench 

Needle nose Pliers 

Scissors 

Awl 

Sander 







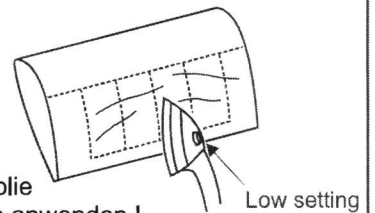

Wire Cutters 

Masking tape - Straight Edged Ruler - Pen or pencil - Drill and Assorted Drill Bits

If exposed to direct sunlight and/or heat, wrinkles can appear. Storing the model in a cool place will let the wrinkles disappear. Otherwise, remove wrinkles in covering film with a hair dryer, starting with low temperature. You can fix the corners by using a hot iron.



Bei Sonneneinstrahlung und/oder Wärme kann die Folie erschlaffen bzw. Falten entstehen. Verwenden Sie ein Warmluftgebläse (Haartrockner) um evtl. Falten aus der Folie zu bekommen. Die Kanten können Sie mit einem Bügeleisen behandeln. Nicht zuviel Hitze anwenden!

 Drill holes using the stated size of drill (in this case 1.5 mm Ø)	 Take particular care here	 Hatched-in areas: remove covering film carefully	 Check during assembly that these parts move freely, without binding
 Use epoxy glue	 Apply cyano glue	 Assemble left and right sides the same way.	 Not included. These parts must be purchased separately





 Löcher bohren mit dem angegebenen Bohrer (hier 1,5 mm)	 Hier besonders aufpassen	 Schraffierte Stellen, Bespannfolie vorsichtig entfernen	 Während des Zusammenbaus immer prüfen, ob sich die Teile auch reibungslos bewegen lassen
 Epoxy-Klebstoff verwenden	 Sekundenkleber auftragen	 Linke und rechte Seite wird gleichermaßen zusammengebaut	 Nicht enthalten. Teile müssen separat gekauft werden.

Read through the manual before you begin, so you will have an overall idea of what to do.

**CONVERSION TABLE**

1.0mm = 3/64"	3.0mm = 1/8"	10mm = 13/32"	25mm = 1"
1.5mm = 1/16"	4.0mm = 5/32"	12mm = 15/32"	30mm = 1-3/16"
2.0mm = 5/64"	5.0mm = 13/64"	15mm = 19/32"	45mm = 1-51/64"
2.5mm = 3/32"	6.0mm = 15/64"	20mm = 51/64"	

# 1- Landing gear / Fahrwerk

- |   |   |  |
|---|---|--|
| 3x12mm screw<br> .....8                      | Stopper (metal)<br> .....2 | 5.5mm Collar<br> .....4 |
| Nylon strap<br>Kunststoffstreifen<br> .....4 | 3mm set screw<br> .....4   |  |

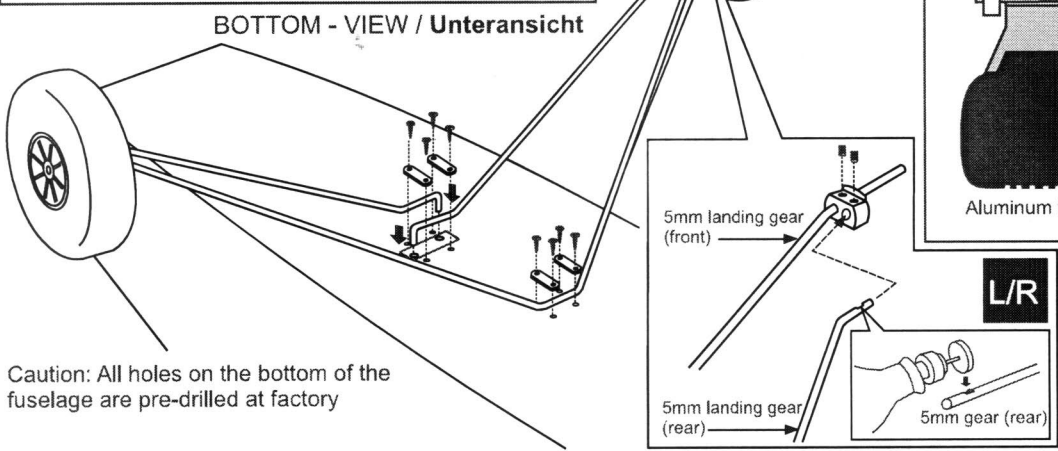
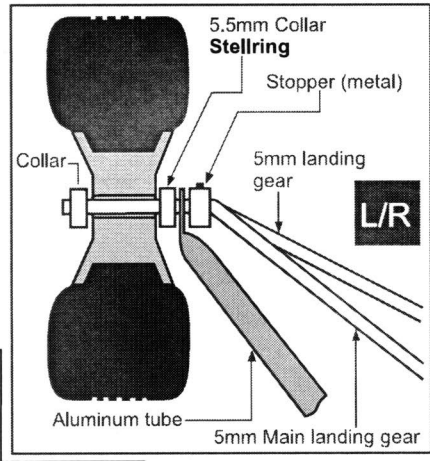

Caution: All holes on the bottom of the fuselage are pre-drilled at factory

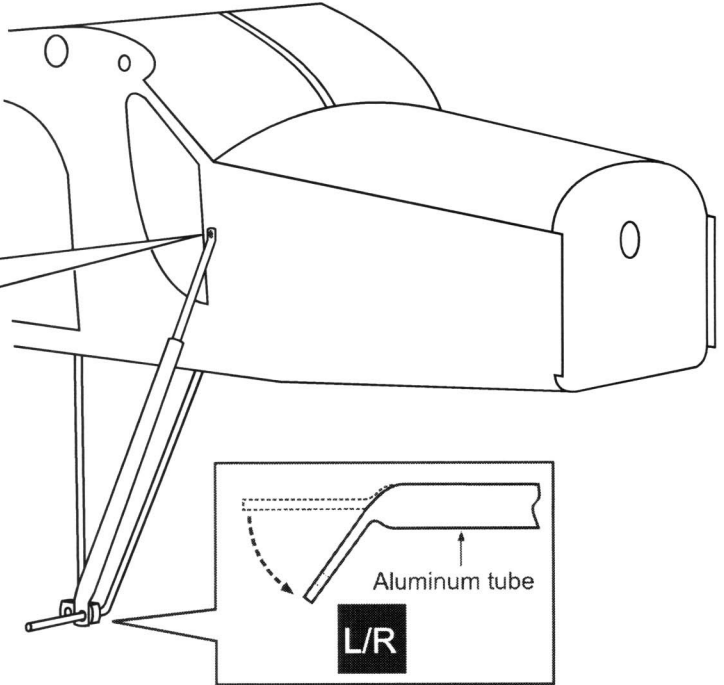
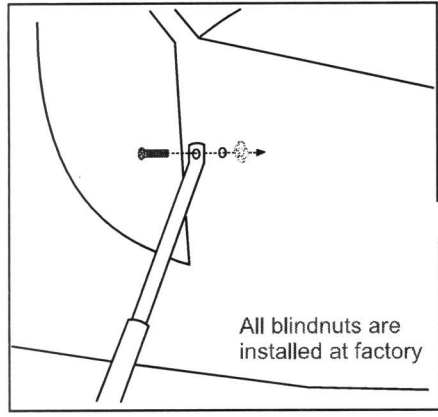

# 2- Landing gear / Fahrwerk



- |   |  |
|---|--|
| 3x15mm screw / Schraube<br> .....2 | Spring.....2                               |
| Main landing gear (5mm).....2<br>Hauptfahrwerk  | Landing gear (5mm).....1<br>Fahrwerksdraht |

Two holes on the left and the right side of the fuselage are pre-drilled at factory



# 3- Tail gear / Heckspornrad

- |   |
|---|
|  Tail gear mount...1 |
|  3x12mm screw.....4  |

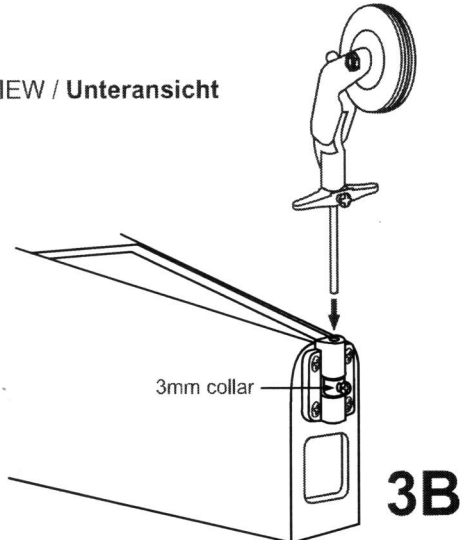
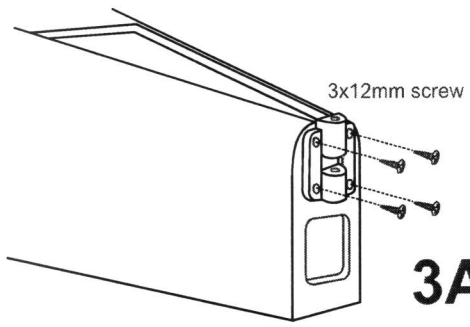
**BOTTOM - VIEW / Unteransicht**



#### 4- Tail gear / Heckspornrad

3x12mm screw	Tail gear control arm
 .....4	 .....2
 .....1	

4A



BOTTOM - VIEW / Unteransicht

4B



Tail gear control horn B      Tail gear push rod

Note: Slide the tail gear push rod in to the hole of the tail gear control horn B first.

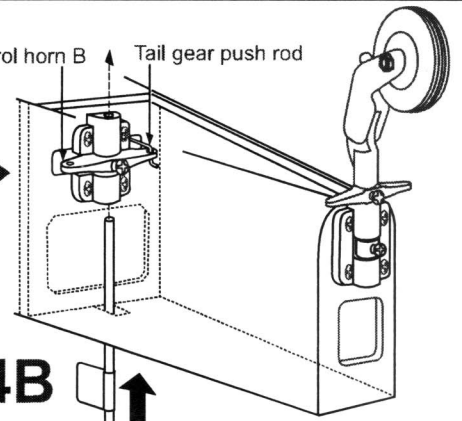

#### 5- Tail gear / Heckspornrad

BOTTOM - VIEW  
Unteransicht

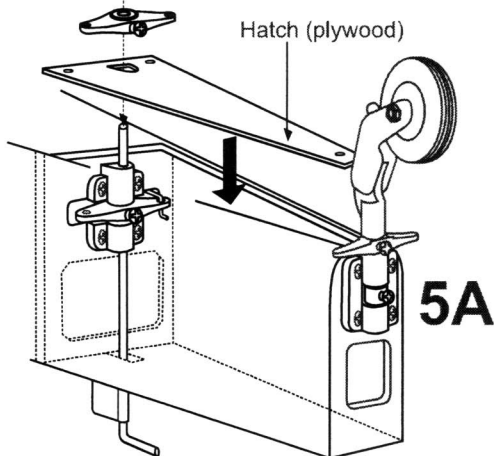

5A

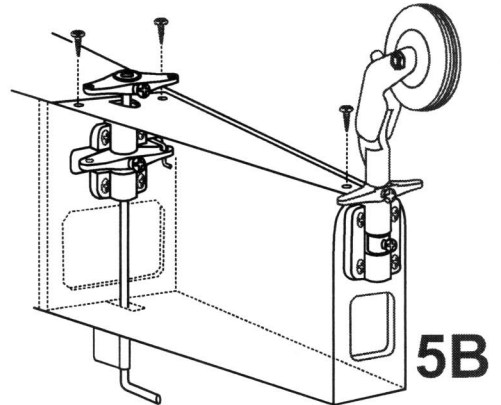

5B

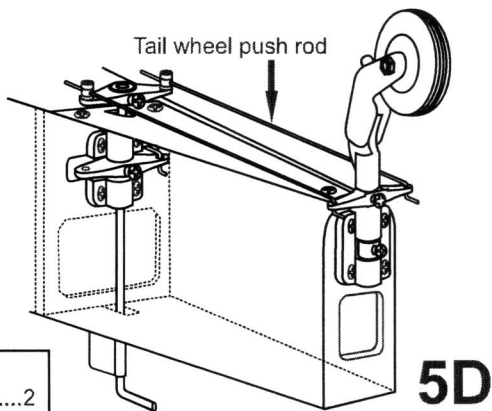

5D

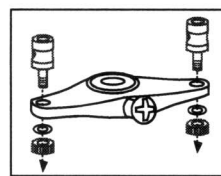

5C

Connector
 .....2

HORIZONTAL STABILIZER

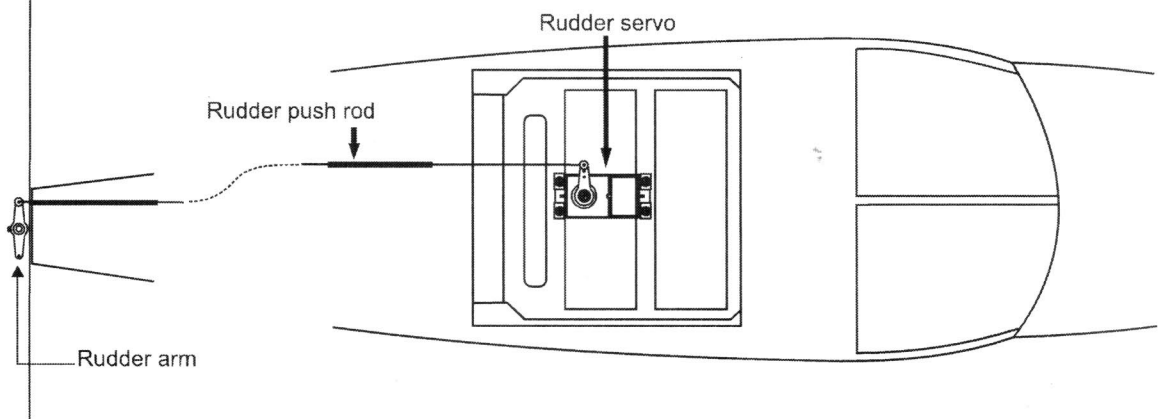

Rudder servo

Rudder push rod

Rudder arm

## 6- Vertical Stabilizer Seitenleiwerk

TOP VIEW / Draufsicht

Cut 7/8" (22mm) long slots along the hinge line in the trailing edge of the vertical stabilizer for the rudder torque rod bearings. Position of the slot on the side of the vertical stabilizer, 2"(50mm) from the bottom (6A)

Test-fit the rudder torque rods into the slot.

NOTE: You may need to open up the slots so that the torque rod bearing are not too difficult to push in

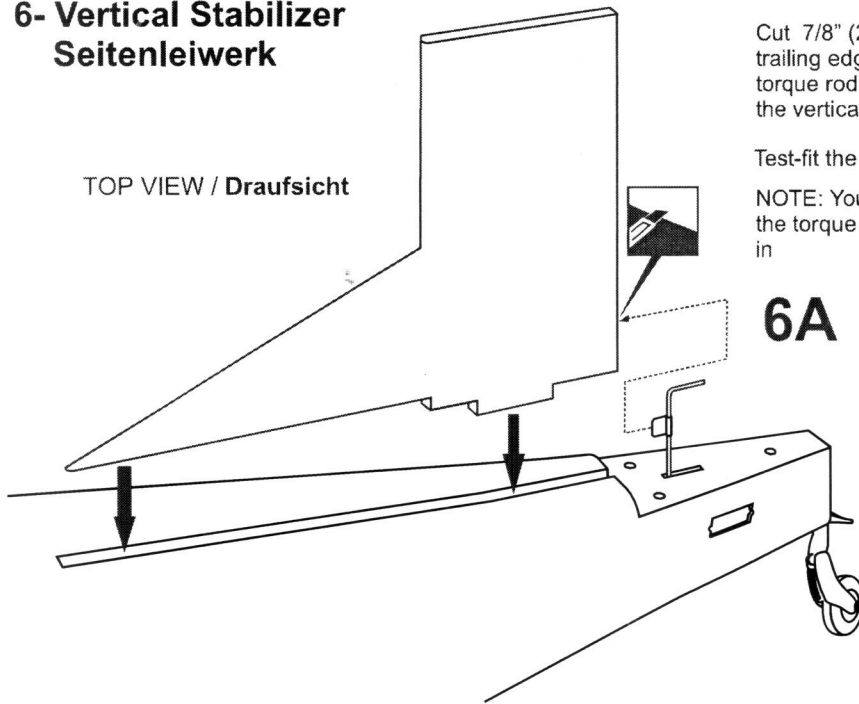

6A

When you are satisfied with the alignment, use a pencil to trace around the left and right of the stabilizer where it meets the fuselage(6B)

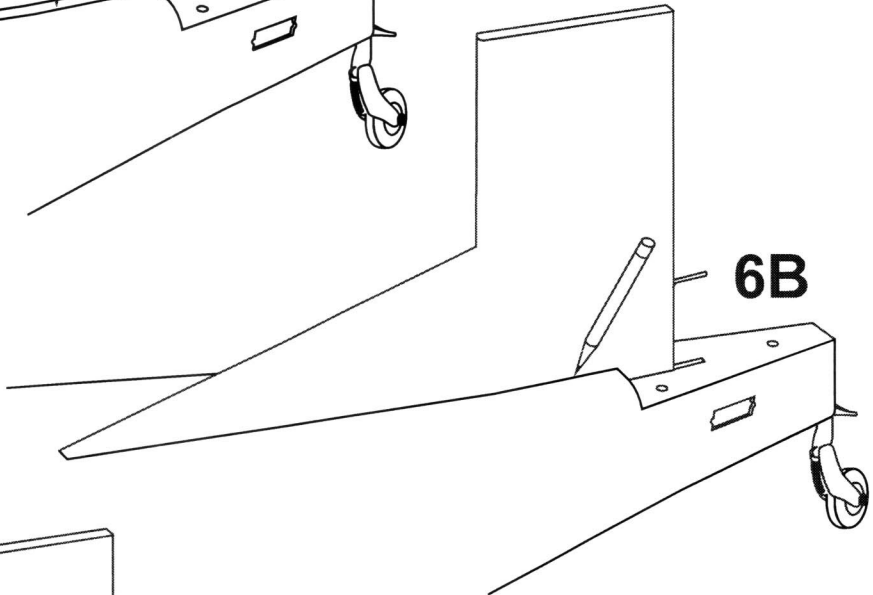

6B

Remove the vertical stabilizer from the fuselage. Using the sharp hobby knife, carefully cut away the covering inside the lines which were marked above(6C)

\* **WARNING:** When removing any covering from the airframe, please ensure that you secure the cut edge with CA or similar cement. This will ensure the covering remain tight.

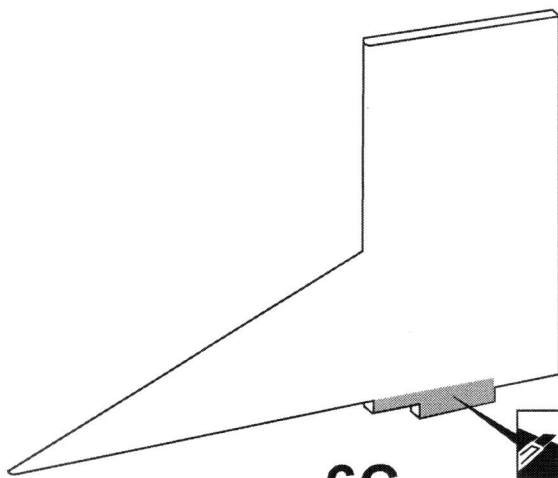

6C

Cut away only the covering both side

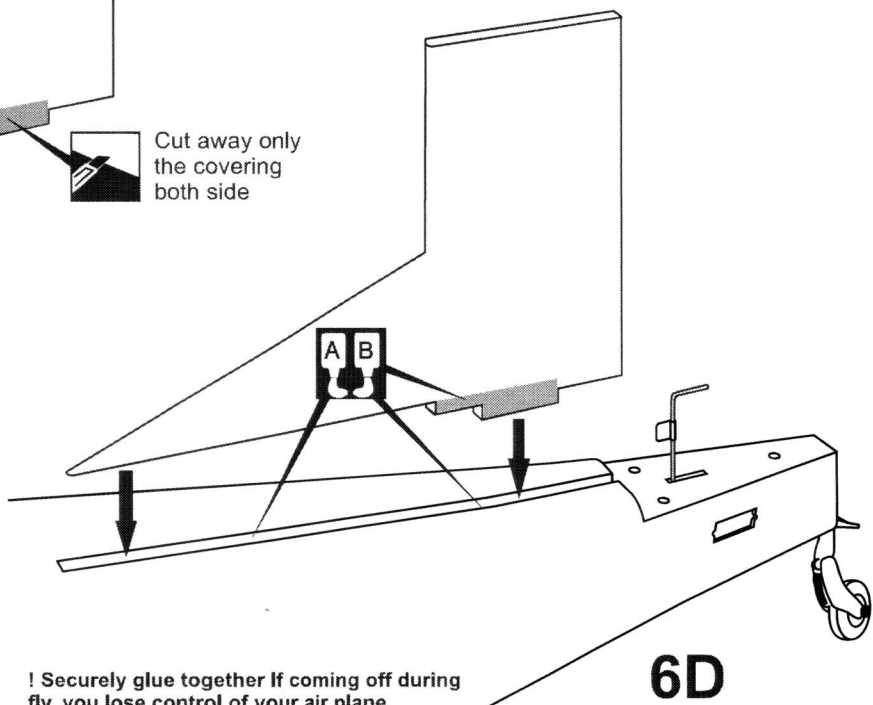
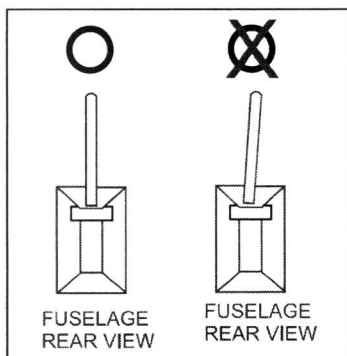

6D

! Securely glue together If coming off during fly, you lose control of your air plane.

## 7- Horizontal Stabilizer Höhenleitwerk

30x4mm nylon bolt

 .....3

7A

Horizontal stabilizer

7B

Using a pencil, mark the rudder where the rudder torque rod meet the rudder.

Cut 2.3" (60mm) long slots along the hinge line in the leading edge of the rudder.

Drill a 3/32" (2.5mm) diameter hole in tail wheel gear mounting slot, marking sure that you drill the hole perpendicular to the leading edge of the rudder (7C).

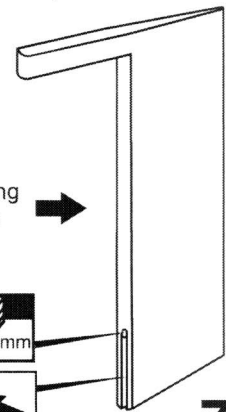

7C

Petroleum jelly



 CA

Thin CA glue

Hinge

STABILIZER

7D

Apply a thin layer of machine oil or petroleum jelly to only the **top and bottom of the trailing edge of the elevator**, then push the rudder and its hinges into the hinge slots in the trailing edge of the vertical stabilizer.

When satisfied with the and alignment, hinge the rudder to the vertical stabilizer using CA glue (7D).

## 8- Horizontal Stabilizer Höhenleitwerk

Control horn	.....2
2x30mm screw	.....4

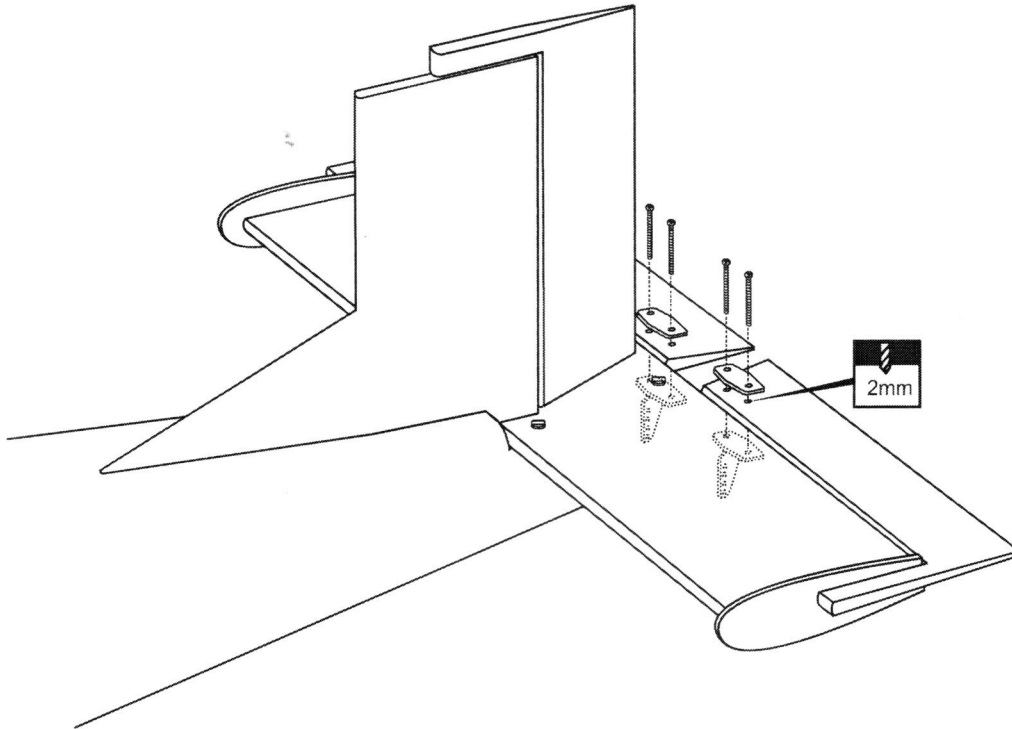

## 9- Servo

BOTTOM - VIEW  
Unteransicht

9A

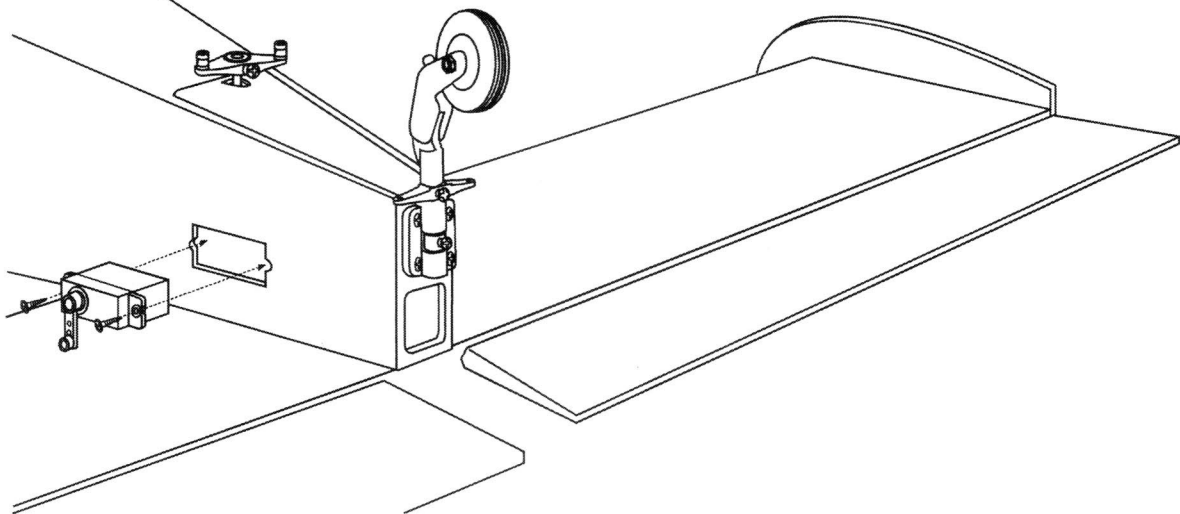

9B

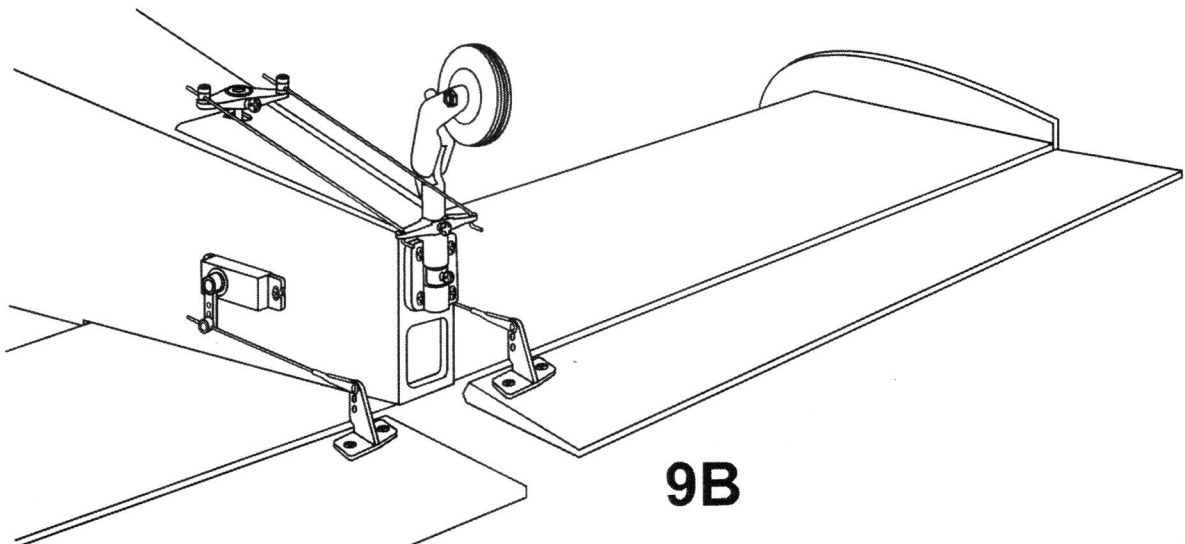

## 10- Engine - Cowl / Motor - Motorhaube

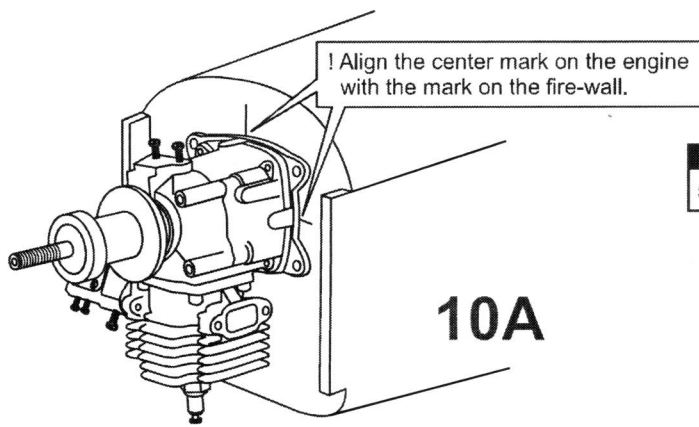

**10A**

Using a pencil or felt tipped pen, mark the fire wall where the four holes are to be drilled (10A).

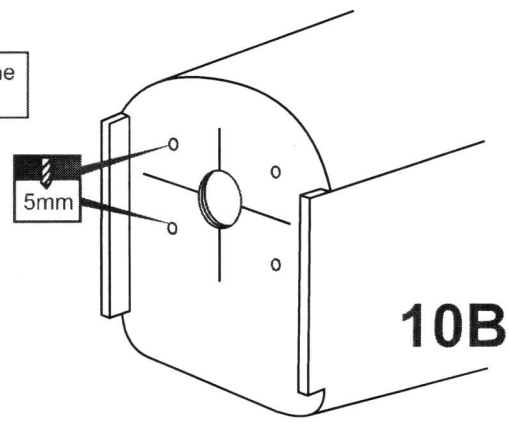

**10B**

Remove the engine mount and drill a 13/64"(5mm) hole through the fire-wall at each of the four marks marked (10B).

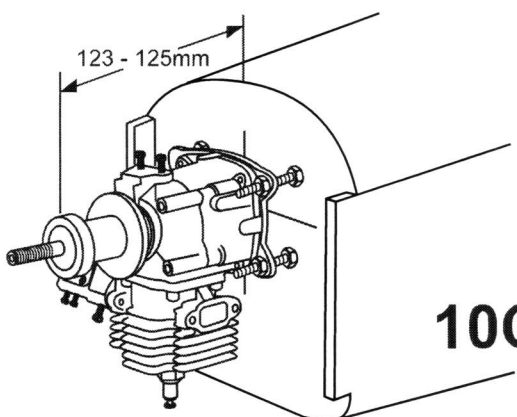

**10C**

Reposition the engine on to the fire-wall so the distance from the prop hub to the fire-wall is 4.8 - 4.9"(123 - 125mm) (10C).

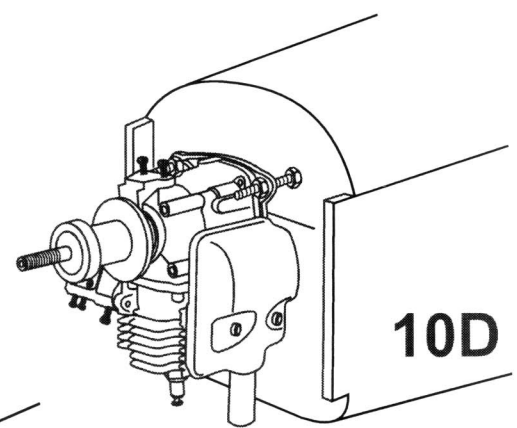

**10D**

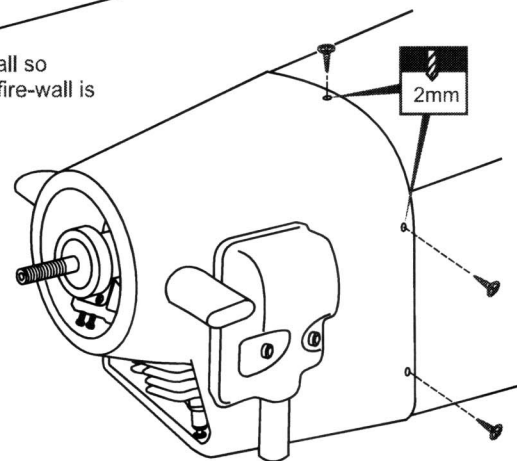

**10E**

3x12mm screw  
 .....5



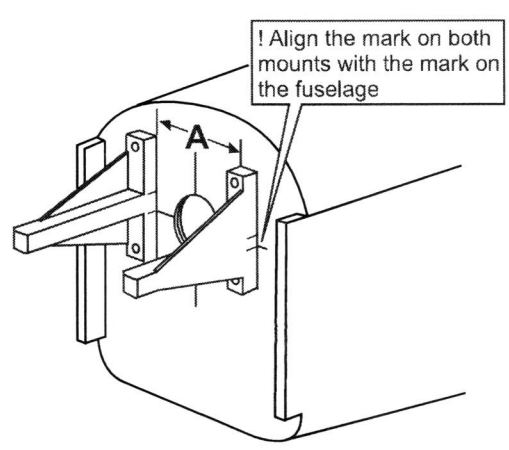

## 11- Glow Engine

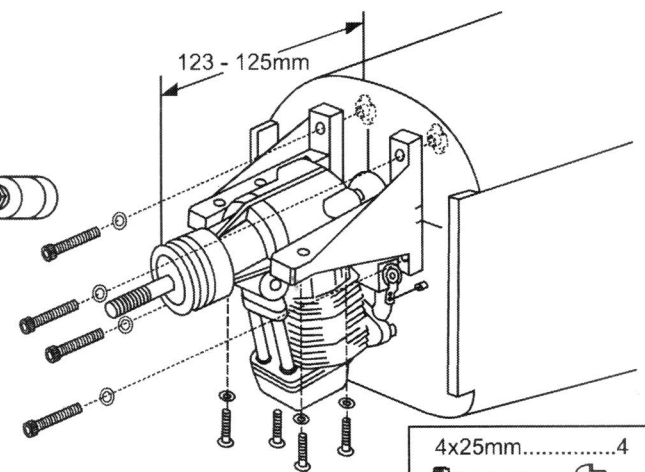
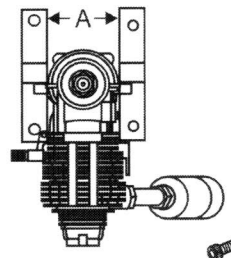

FRONT-VIEW



Using a pencil or felt tipped pen, mark the fire wall where the four holes are to be drilled  
 Remove the engine mount and drill a 5mm hole through the fire-wall at each of the four marks marked.  
 Attach the four blind-nut to the fire-wall as show.

4x25mm.....4  
   
 3x20mm.....4  
 



## 12- Brushless Motor

- Using a plywood motor mounting plate as a template, mark the fire wall where the four holes are to be drilled (12A).
- Remove the plywood motor mounting plate and drill a 13/64"(5mm) hole through the fire-wall at each of the four marks marked (12B).
- Using an aluminum motor mounting plate as a template, mark the plywood motor mounting plate where the four holes are to be drilled (12C).
- Remove the aluminum motor mounting plate and drill a 1/8"(3mm) hole through the plywood at each of the four marks marked (12D).

Plywood motor mounting plate  
Sperrholztrager Platten

FRONT-VIEW  
Vorderansicht

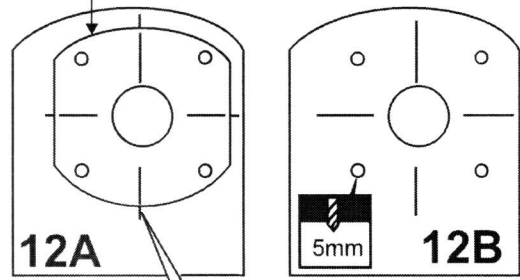

! Align with the marks  
An den Markierungen ausrichten

Montagekreuz aus  
Alu (nicht enthalten)

Aluminum motor  
mounting plate

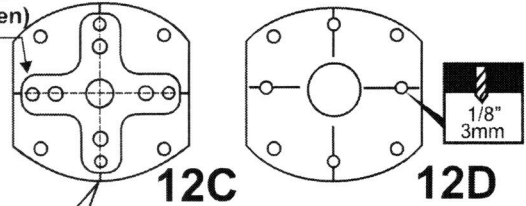

! Align with the marks  
An den Markierungen ausrichten

5x70mm.....4      4mm.....x12

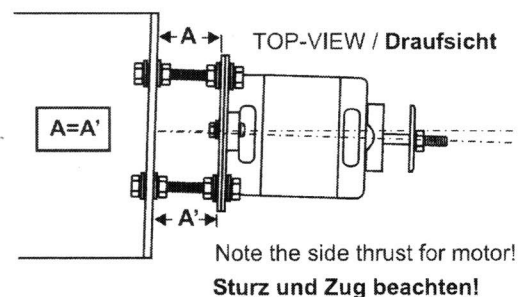
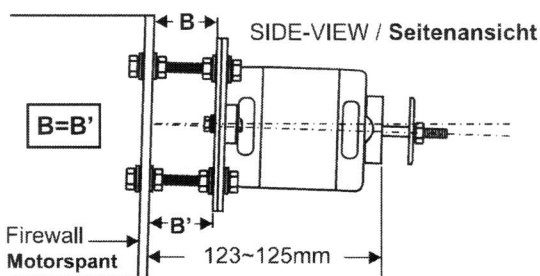
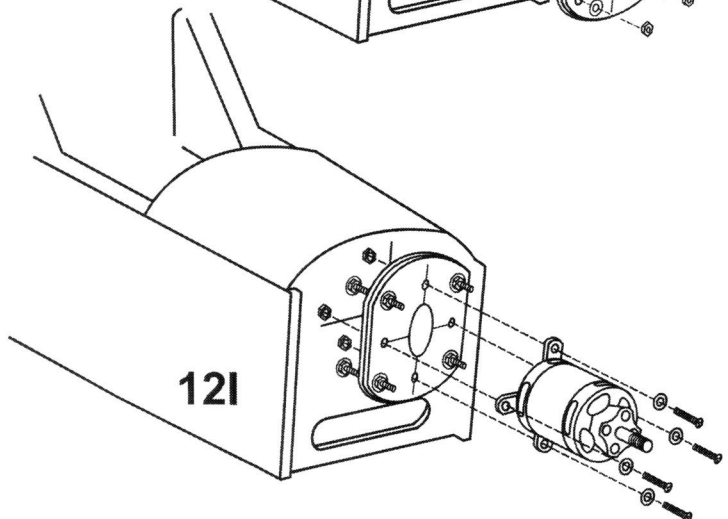
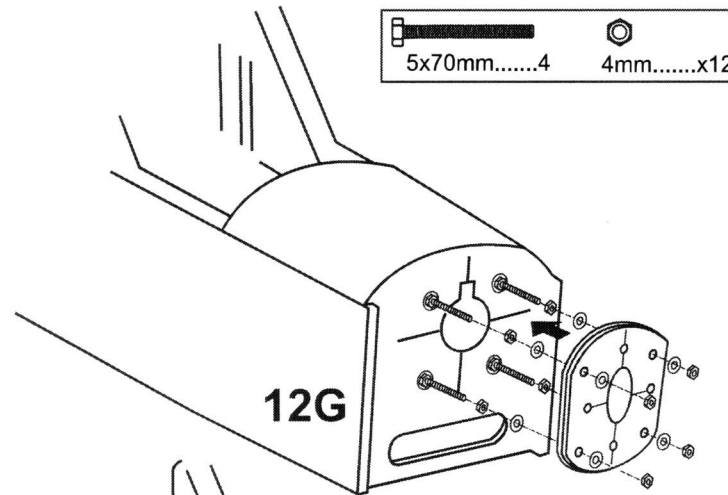
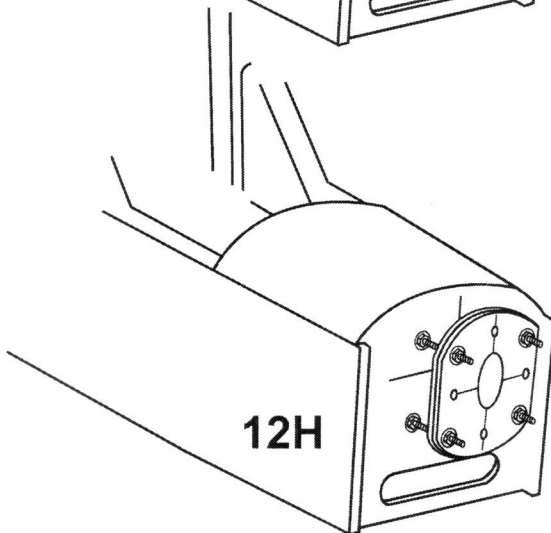
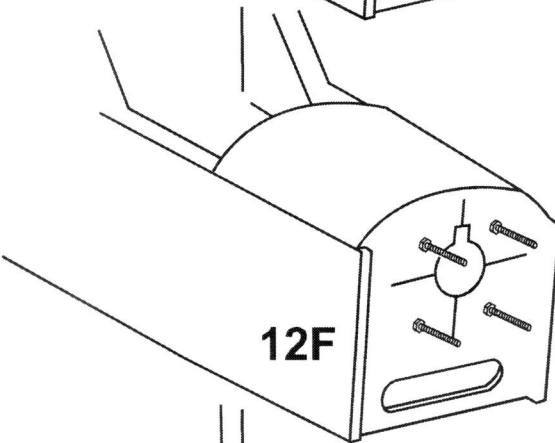
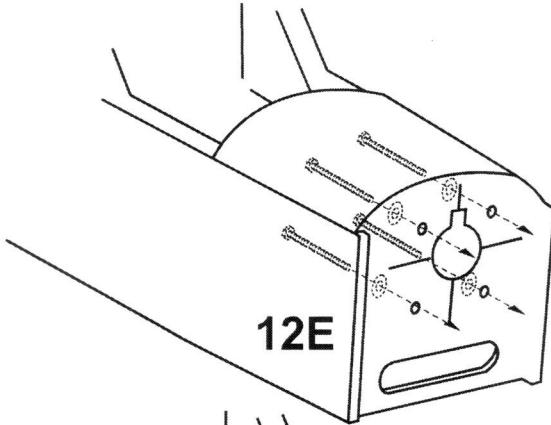

### 13- Fuel tank / Tankeinbau

Full the magnetic battery hatch out of the fuselage.

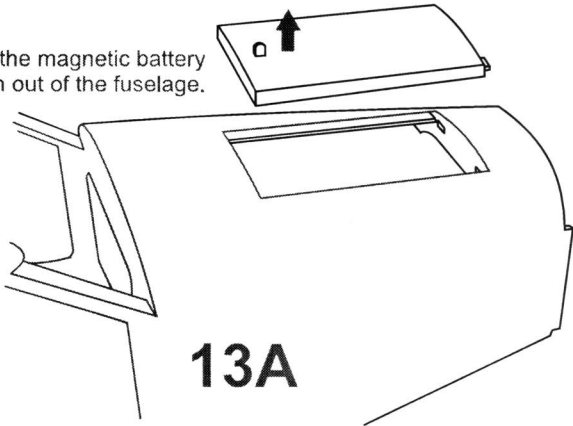

**13A**

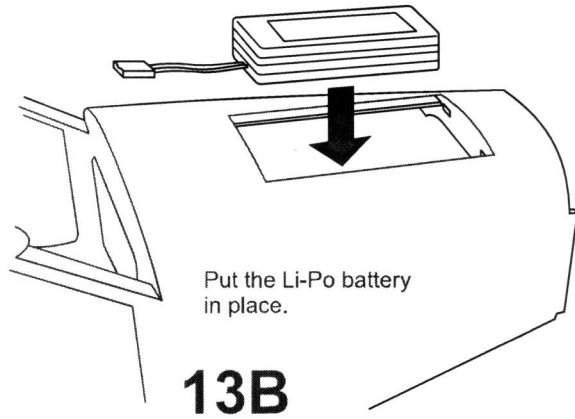

Put the Li-Po battery in place.

**13B**

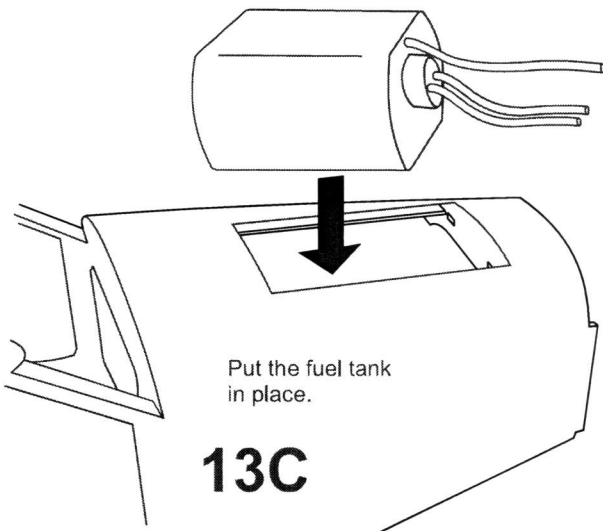

Put the fuel tank in place.

**13C**

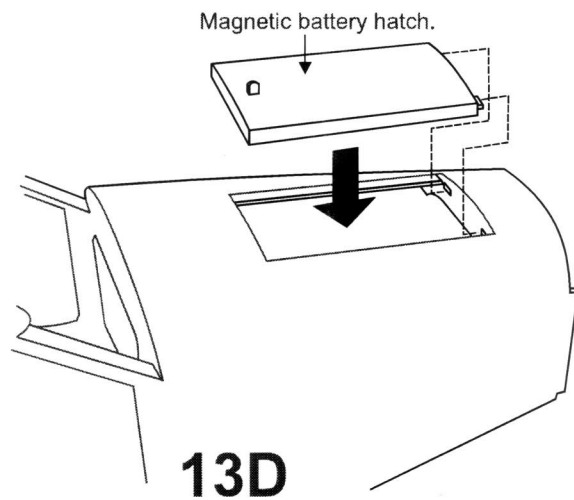

Magnetic battery hatch.

**13D**

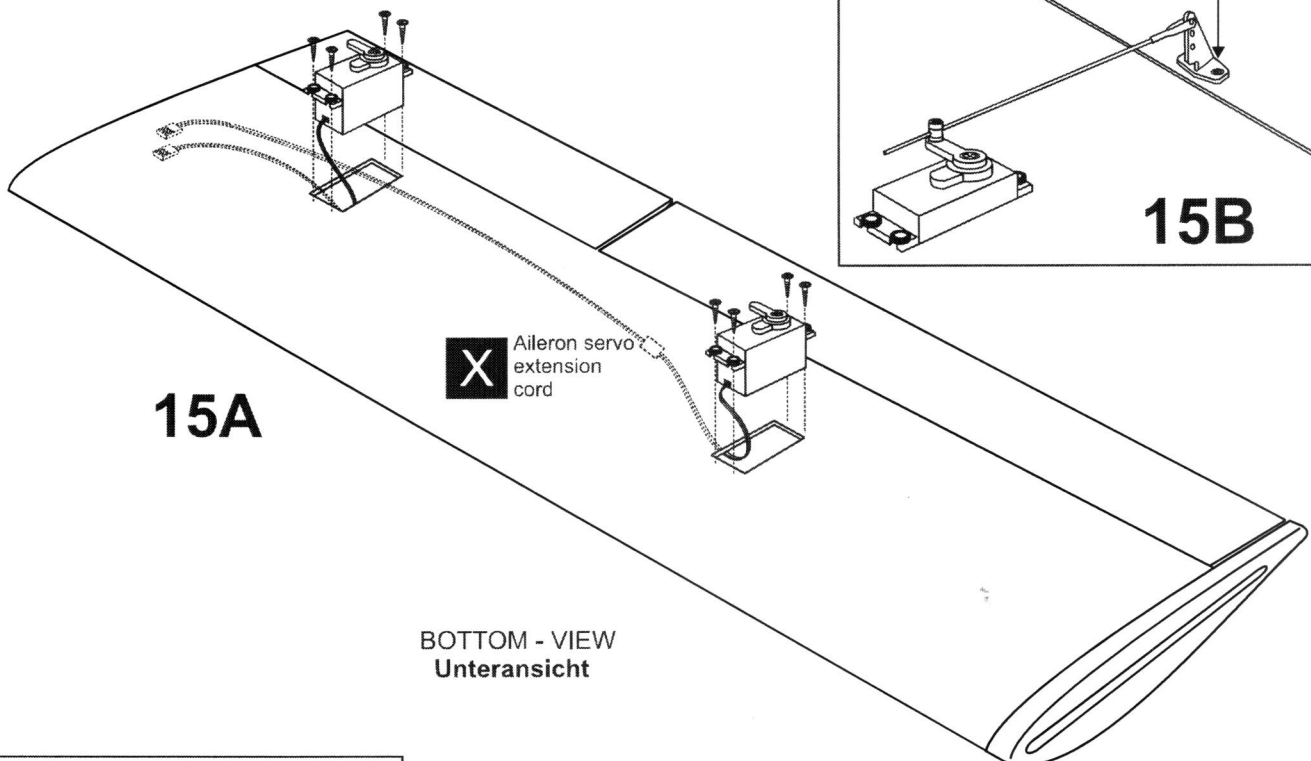

### 15- Servo



**15A**

**15B**

BOTTOM - VIEW  
Unteransicht

	Control horn		2x30mm screw
.....2		.....4	
		.....2	

## 14- Installing the wing / Tragflächeneinbau

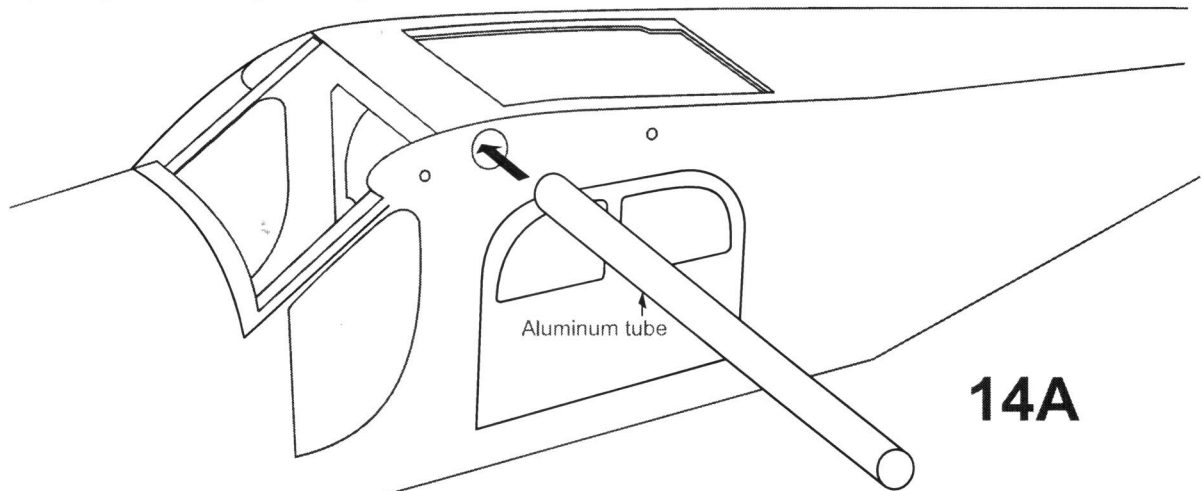

14A

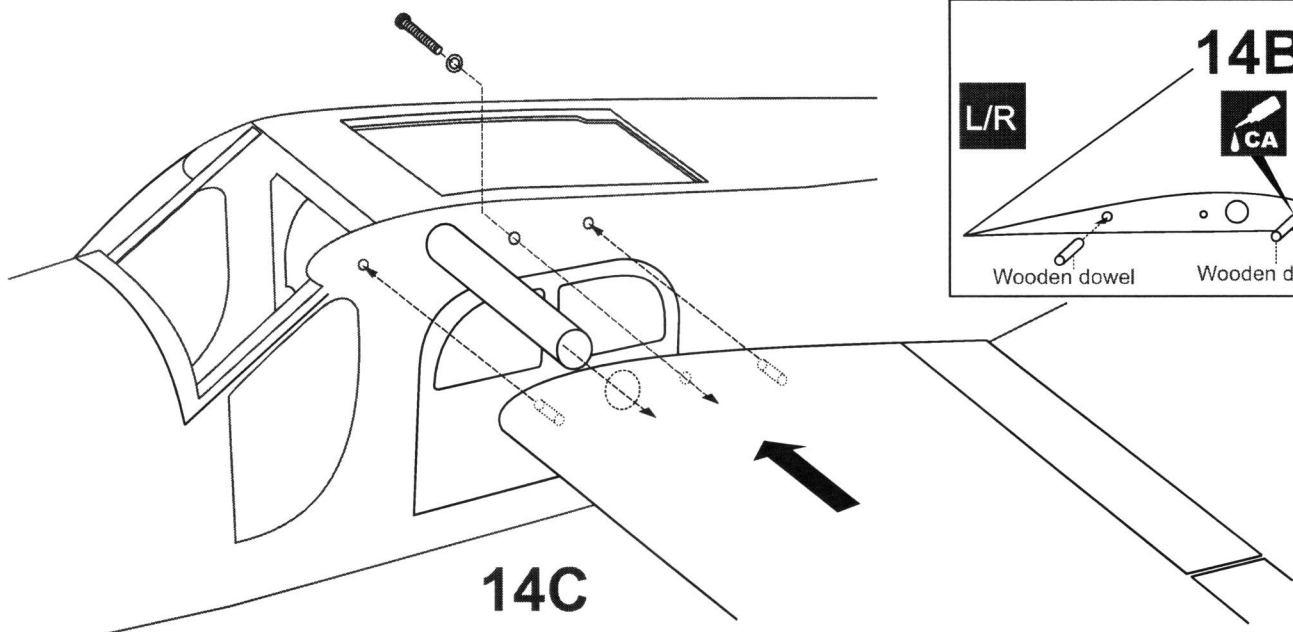

14C

## 16- Installing the wing / Tragflächeneinbau

3x15mm screw / Schraube

.....2



.....2

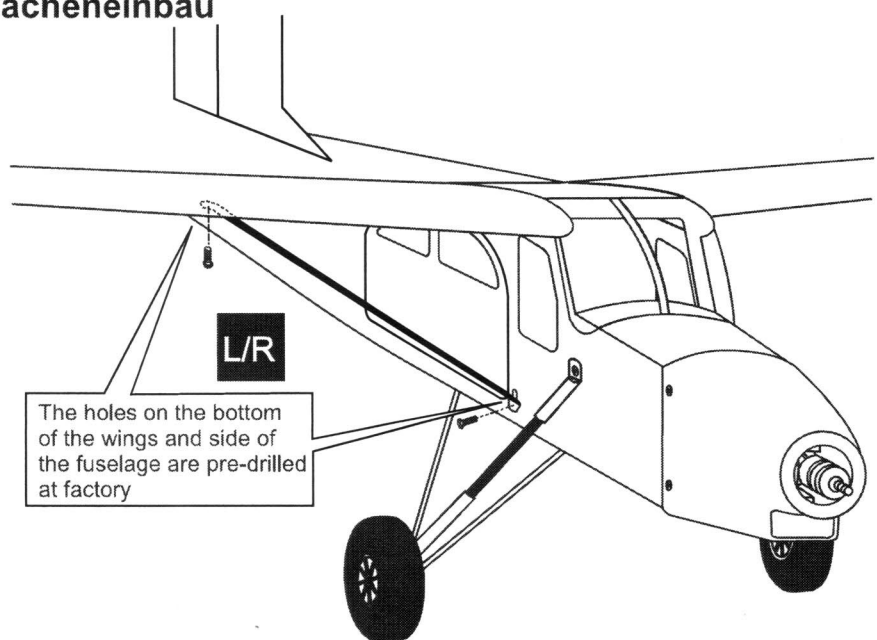
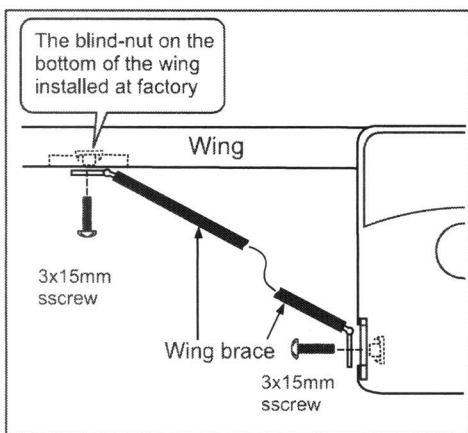

To the bottom of the wing

To the side of the fuselage



Wing brace ( right - left )

## 17- Decor / Aufkleber

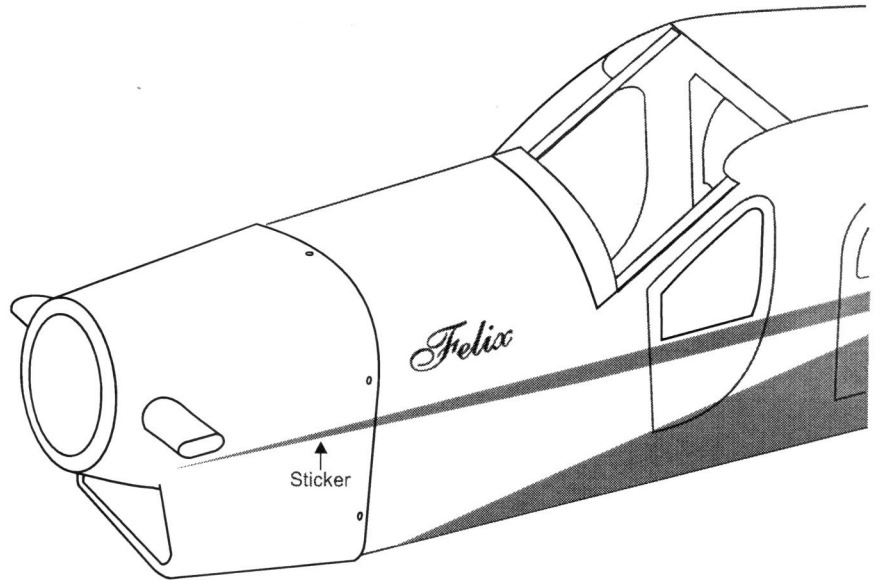

### IMPORTANT:

Please do not clean your model with pure alcohol, only use liquid soap with water or use glass cleaner to clean on surface of your model to keep the colour not fade.

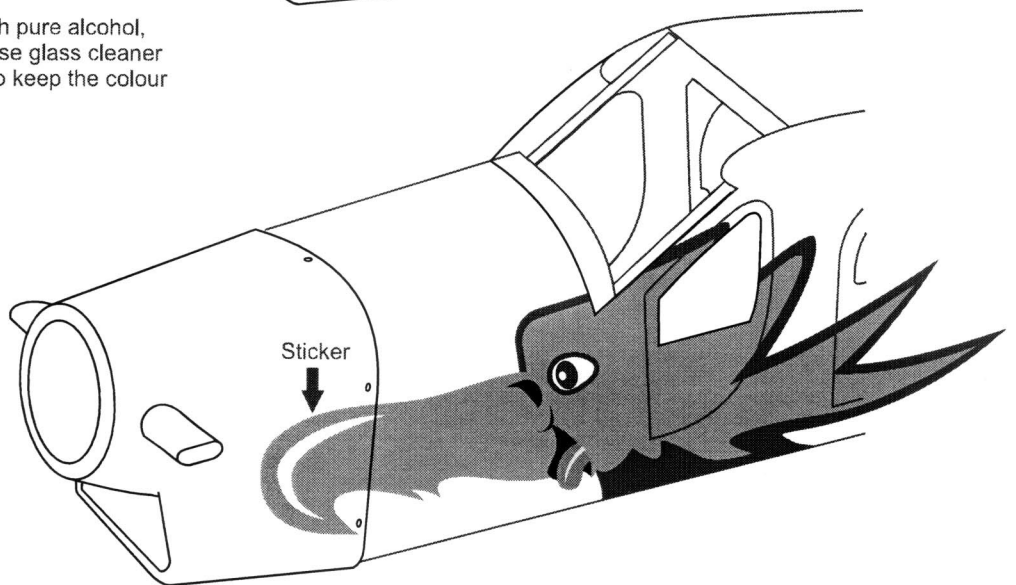

All details are subject to change without notice !

Technische Änderungen und Irrtümer vorbehalten !

## 18- Balance / Schwerpunkt

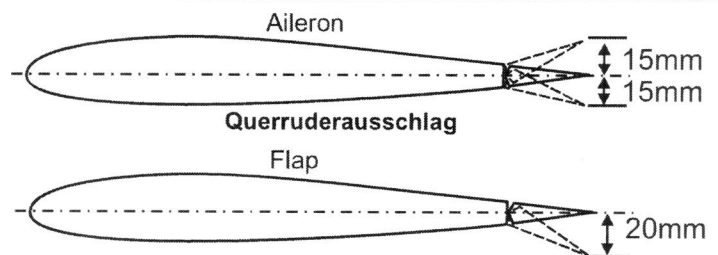
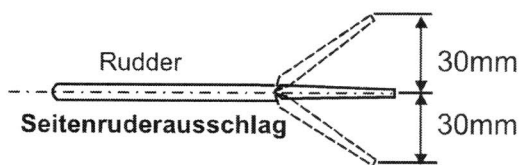

Do not try to fly an out-of balance model!  
Überprüfen Sie vor dem Flug den Schwerpunkt.

